



**ILLINOIS STATE UNIVERSITY
EXHIBIT FS-10.1: SIGN STANDARDS**

Effective February 1, 2023

I. SIGNS

- A. All design and construction projects should include a wayfinding component. Illinois State University's Signage and Wayfinding standards should be implemented for all Illinois State University facilities. Exterior and interior "wayfinding" should provide direction to users of the campus and will be part of renovation and construction projects.
- B. A meeting with Illinois State University Facilities Planning, Design, and Construction (ISU FPDC) to review ISU signage requirements and standards is required for all projects. Obtain ISU FPDC's written approval for signage.
1. Sign standards are currently being updated. Attached examples are subject to change. Confirm sign requirements at the separate sign meeting with ISU FPDC.
- C. Signage and Wayfinding Elements:
1. Sign Types:
 - a) E = Exterior
 - b) ID = Room Identification
 - c) RR = Restroom Identification
 - d) W = Wayfinding
 - e) RG = Regulatory
 - f) D = Directory
 - g) DP = Donor Plaques
 - h) M = Miscellaneous
 2. Exterior Building Identification Sign (E): New exterior building signs shall be provided for new construction or major renovations. Exterior signs will be located outside main entry to building at median near street. Additional building signs may be included on quad side or walking paths to support building identification. Final location of all building signs shall be incorporated into landscaping plans and confirmed in writing with Facilities Planning, Design, and Construction.
 - a) Referenced Drawings:
 - (1) E-1 Exterior Sign with One Line
 - (2) EW-1 Exterior – Wayfinding Sign



FACILITIES PLANNING, DESIGN, AND CONSTRUCTION

Illinois State University

3. Room Identification (ID): All room signs shall be located on the side of the door frame, never on the door itself, and as required to meet accessibility.
 - a) Typical Room Signs: Typical signs shall be attached by double-sided tape to the drywall or other wall surface.
 - b) Room Signs located in Housing: Housing signs shall be mechanically attached to the wall to prevent unwanted removal. Provide four pre-drilled holes with four tamper proof screw attachments.
 - c) Mounting Location: Mount room signs 9” from the door edge to the centerline of the sign and at a height that complies with the current ADA requirements.
 - d) Referenced Drawings:
 - (1) ID-1 Room Identification – Number Only
 - (2) ID-1.1 Room Identification – Exit
 - (3) ID-2 Room Identification – Electrical
 - (4) ID-2.1 Room Identification – Janitorial
 - (5) ID-2.2 Room Identification – Telecom
 - (6) ID-2.3 Room Identification – Mechanical
 - (7) ID-2.4 Room Identification – Building Name
 - (8) ID-2.5 Room Identification – Printer Station
 - (9) ID-2.6 Room Identification – Scanner Station
 - (10) ID-2.7 Room Identification – Locker
 - (11) ID-2.8 Room Identification – Maximum Occupancy
 - (12) ID-3 Room Identification – Insert Name – 6 1/2” Wide
 - (13) ID-3.1 Room Identification – Insert Name – 8 1/2” Wide
 - (14) ID-3.2 Room Identification – Insert Name – 8 1/2” Wide – Arrow
 - (15) ID-4 Room Identification – Conference Slider

4. Restroom Identification (RR): All restroom signs shall be located on the side of the door frame, never on the door itself, and as required to meet accessibility.
 - a) Typical Room Signs: Typical signs shall be attached by double-sided tape to the drywall or other wall surface.
 - b) Room Signs located in Housing: Housing signs shall be mechanically attached to the wall to prevent unwanted removal. Provide four pre-drilled holes with four tamper proof screw attachments.
 - c) Mounting Location: Mount restroom signs 9” from the door edge to the centerline of the sign and at a height that complies with the current ADA requirements.
 - d) Referenced Drawings:
 - (1) RR-1 Restroom Identification – Accessible – Women
 - (2) RR-1.1 Restroom Identification – Women
 - (3) RR-2 Restroom Identification – Accessible – Men
 - (4) RR-2.1 Restroom Identification – Men
 - (5) RR-3 Restroom Identification – Accessible – Girls



- (6) RR-3.1 Restroom Identification – Girls
 - (7) RR-4 Restroom Identification – Accessible – Boys
 - (8) RR-4.1 Restroom Identification – Boys
 - (9) RR-5 Restroom Identification – Accessible – All Gender
 - (10) RR-5.1 Restroom Identification – All Gender
 - (11) RR-6 Restroom Identification – Accessible – Baby Changing Station – Women
 - (12) RR-6.1 Restroom Identification – Baby Changing Station – Women
 - (13) RR-7 Restroom Identification – Accessible – Baby Changing Station – Men
 - (14) RR-7.1 Restroom Identification – Baby Changing Station – Men
 - (15) RR-8 Restroom Identification – Accessible – Baby Changing Station – All Gender
 - (16) RR-8.1 Restroom Identification – Baby Changing Station – All Gender
5. Wayfinding (W): Wayfinding signage will be designed to support circulation through facilities and identification of resources located within buildings.
- a) Referenced Drawings:
 - (1) W-1 Wayfinding – Wall Mounted Sign – Portrait
 - (2) W-1.1 Wayfinding – Wall Mounted – Landscape
 - (3) W-2 Wayfinding – Flag Sign – Accessible – Women
 - (4) W-2.1 Wayfinding – Flag Sign – Women
 - (5) W-3 Wayfinding – Flag Sign – Accessible – Men
 - (6) W-3.1 Wayfinding – Flag Sign – Men
 - (7) W-4 Wayfinding – Flag Sign – Accessible – All Gender
 - (8) W-4.1 Wayfinding – Flag Sign – All Gender
 - (9) W-5 Wayfinding – Flag Sign – Women, Men, Accessible
 - (10) W-5.1 Wayfinding – Flag Sign – Women & Men
6. Regulatory signage (RG): Regulatory signage are sign types to identify required resources and specific characteristics within facilities.
- a) Stairwell Identification and Stair Floor Numbering:
 - (1) Referenced Drawings:
 - (a) RG-1 Stair Identification – Corridor
 - (b) RG-1.1 Stair Identification – In Case of Fire Use Stairs
 - (c) RG-1.2 Stair Identification – Floor Number
 - b) Lactation Room:
 - (1) Referenced Drawings:
 - (a) RG-2 Lactation Sign



FACILITIES PLANNING, DESIGN, AND CONSTRUCTION

Illinois State University

- c) Emergency:
 - (1) Referenced Drawings:
 - (a) RG-4 Regulatory – Emergency Guide – Portrait
 - d) Area of Rescue
 - e) Evacuation Map
- 7. Building Directory (D): Building Directories shall be located at the main entrance or entrances of a building.
 - (1) Referenced Drawings:
 - (a) D-1 Directory – Wall Mounted
- 8. Donor Plaques (DP): Donor Plaque signage are sign types to identify donors.
 - (1) Referenced Drawings:
 - (a) DP-1 Donor – Plaque – Individual
 - (b) DP-2 Donor – Wall – Lettering
- 9. Miscellaneous signage (M): Miscellaneous signage are additional signs specifically requested.
 - a) Referenced Drawings:
 - (1) M-1 Memo Holder – 9” x 11 1/4”

Exterior Sign with One Line

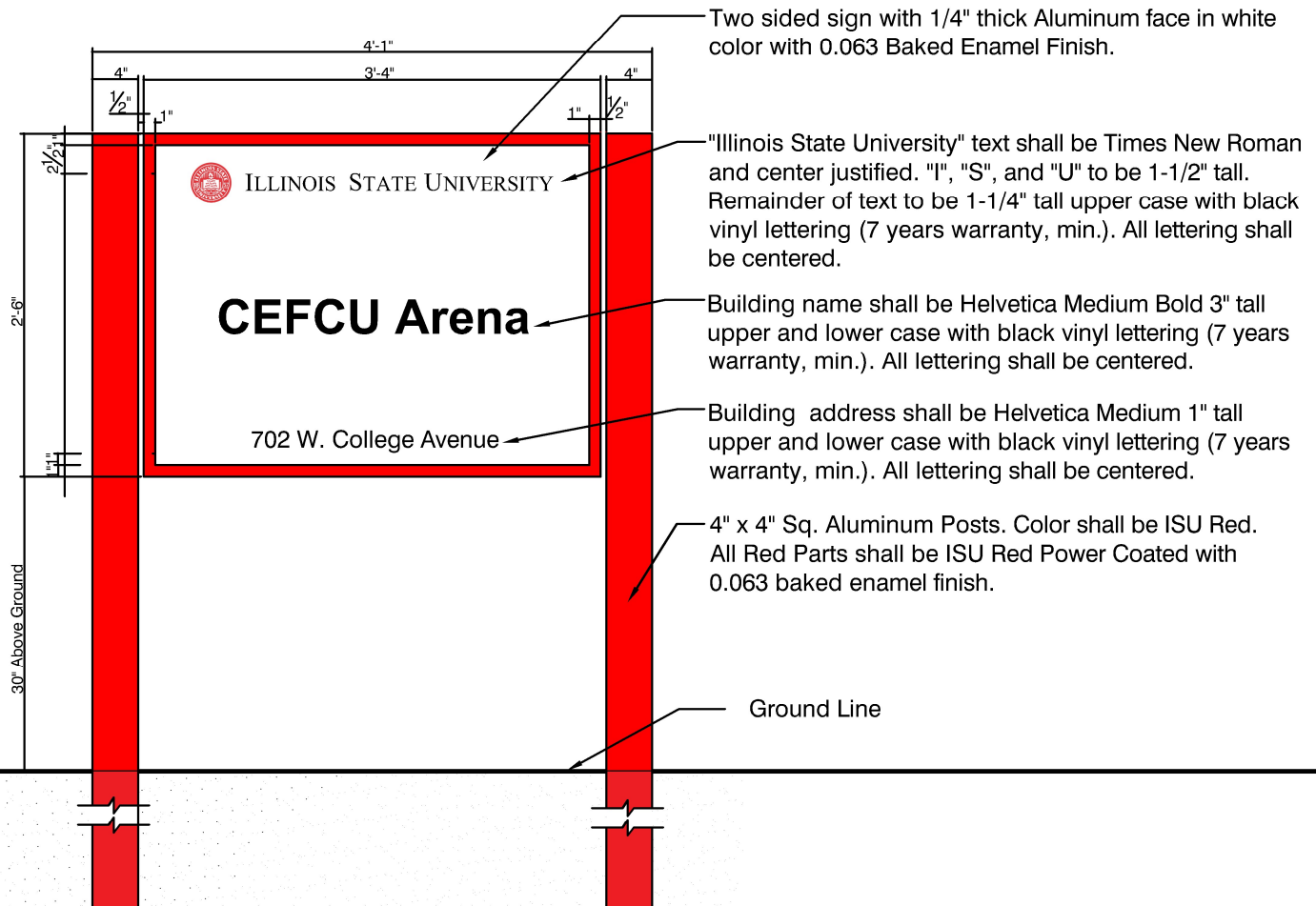

EXTERIOR BUILDING SIGN WITH ONE LINE

NOT TO SCALE

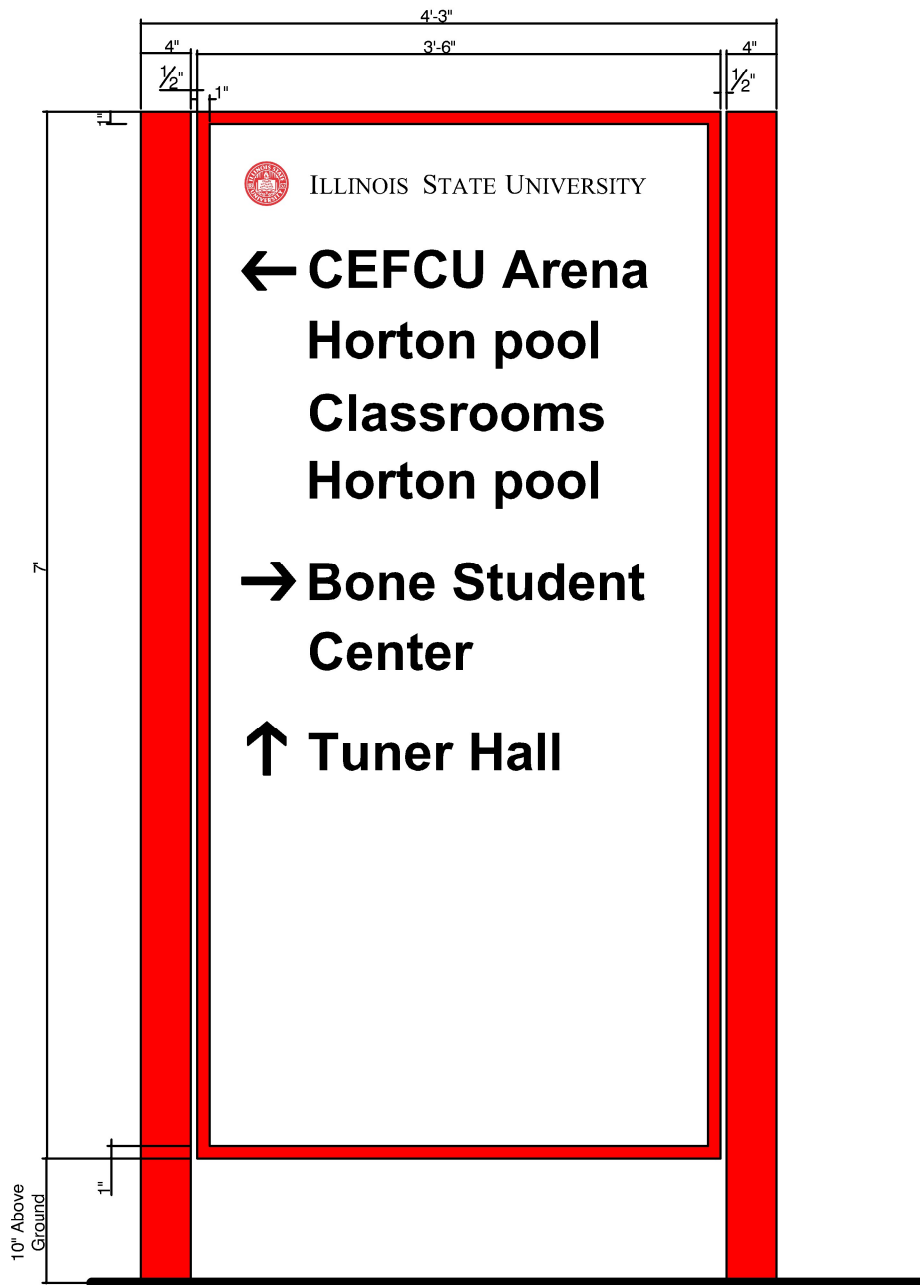

EXTERIOR WAYFINDING SIGN

NOT TO SCALE

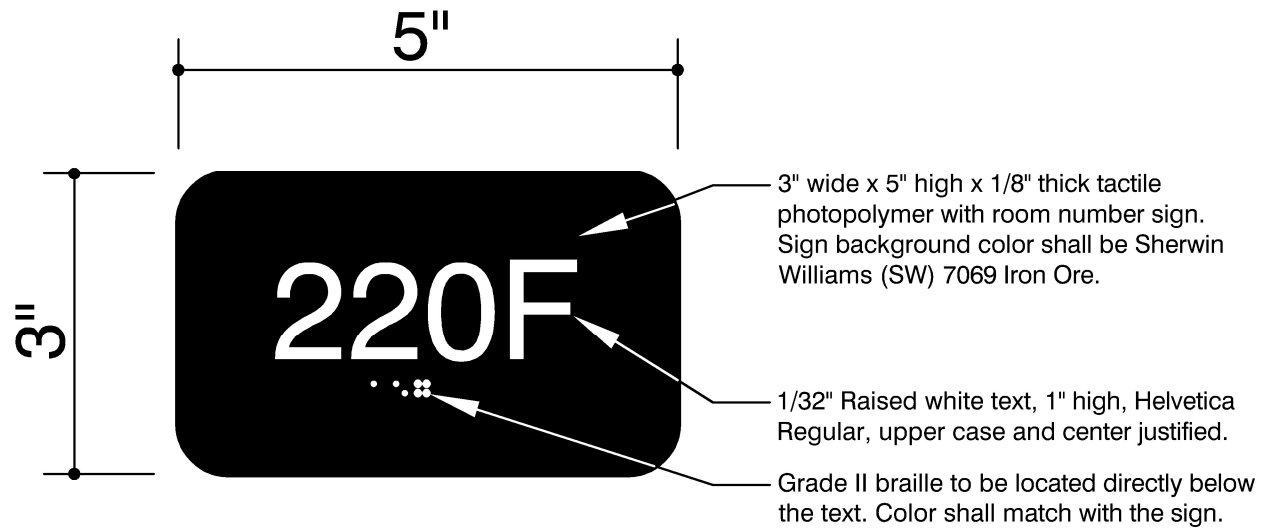

Requirements:

- Submit sample to ISU for approval.
- All signs to meet ADA requirements.
- Two strips of double sided 3 M VHB tape mounting to be included unless otherwise noted.

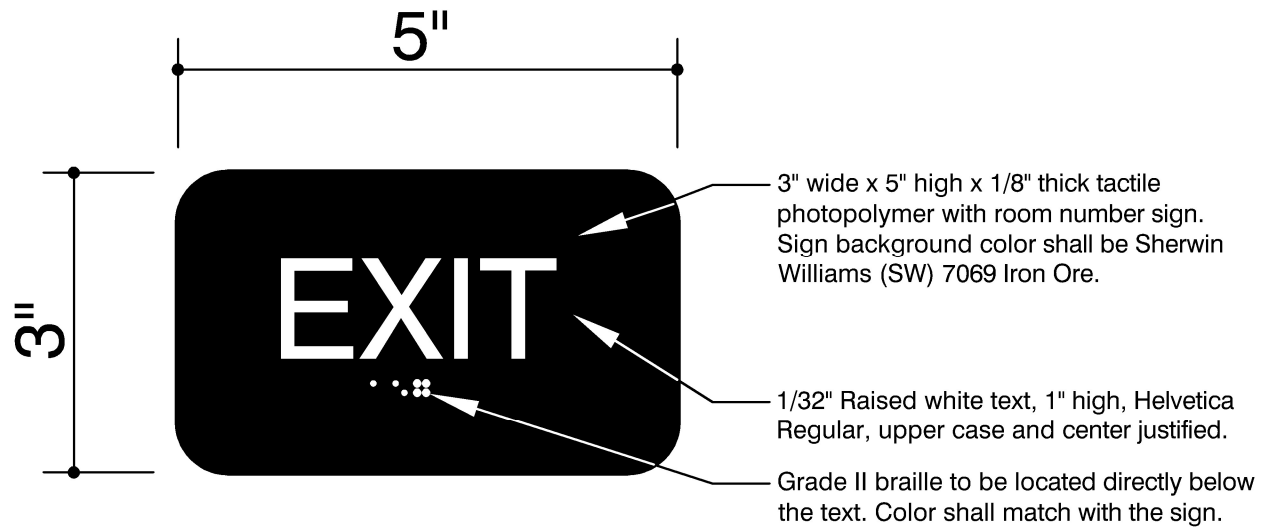

Requirements:

- Submit sample to ISU for approval.
- All signs to meet ADA requirements.
- Two strips of double sided 3 M VHB tape mounting to be included unless otherwise noted.

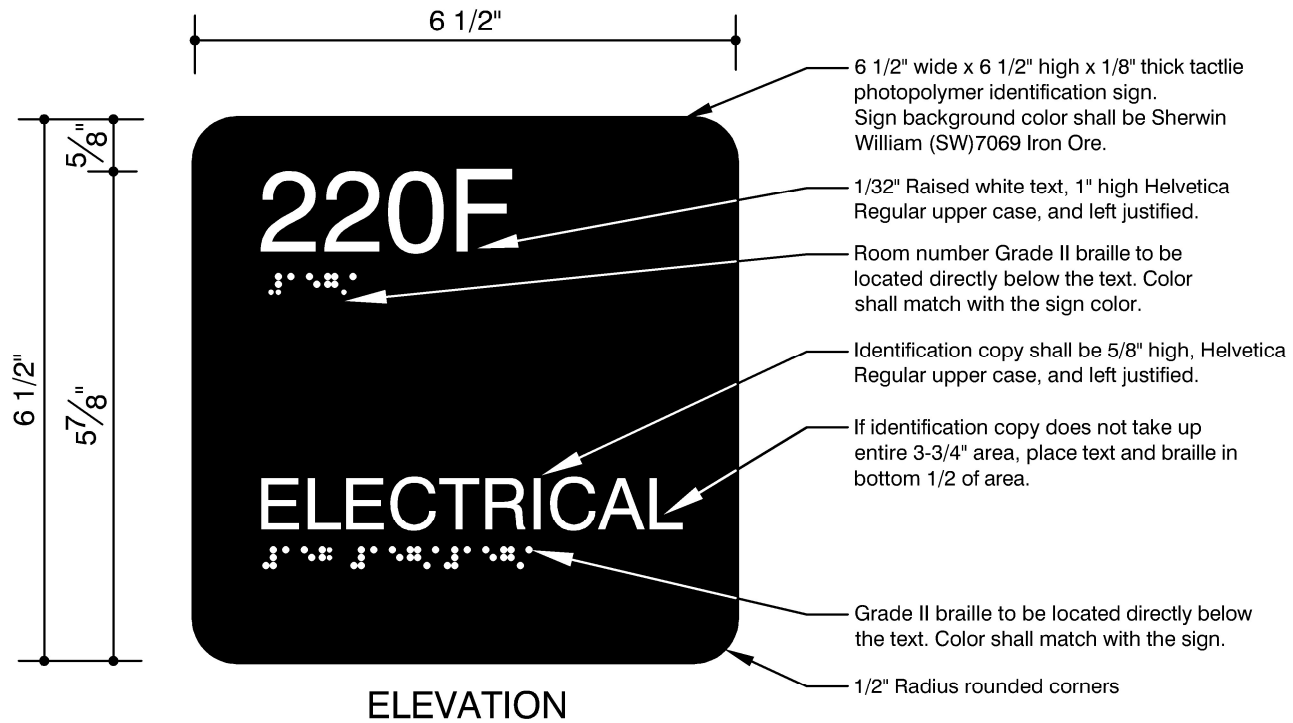

Requirements:

- Submit sample to ISU for approval.
- All signs to meet ADA requirements.
- Two strips of double sided 3 M VHB tape mounting to be included unless otherwise noted.

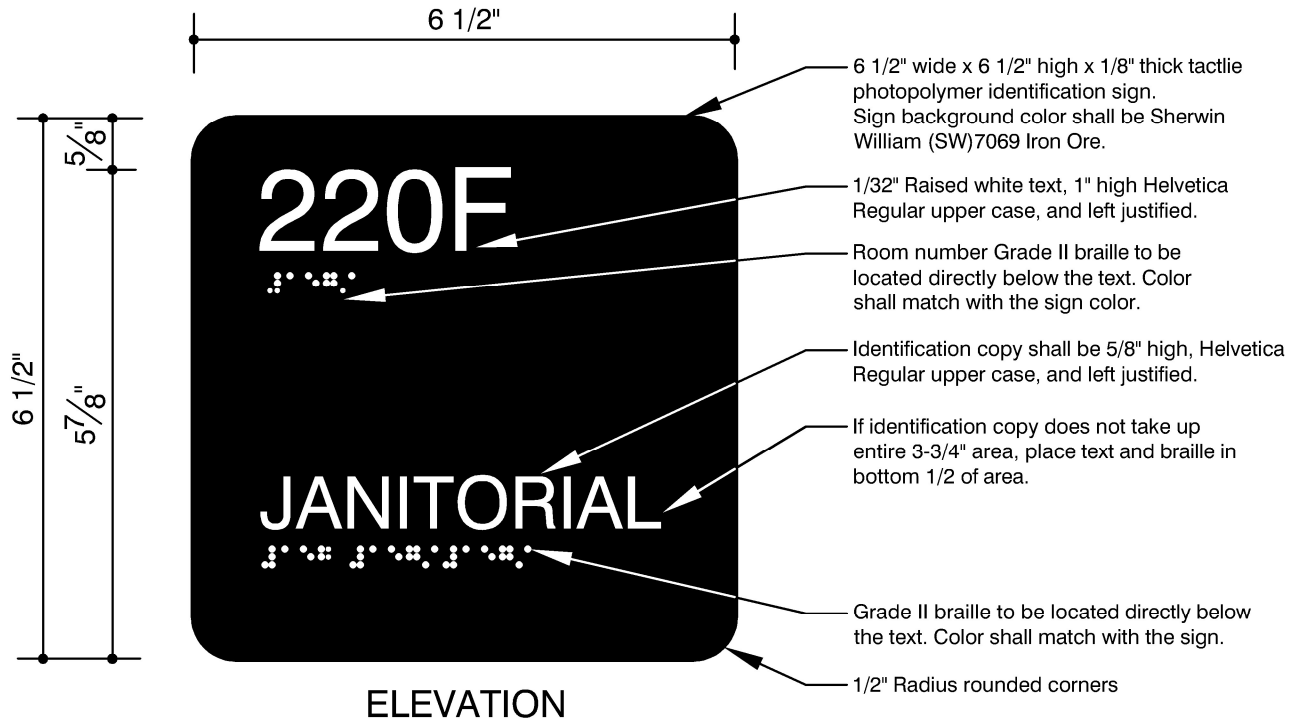

Requirements:

- Submit sample to ISU for approval.
- All signs to meet ADA requirements.
- Two strips of double sided 3 M VHB tape mounting to be included unless otherwise noted.

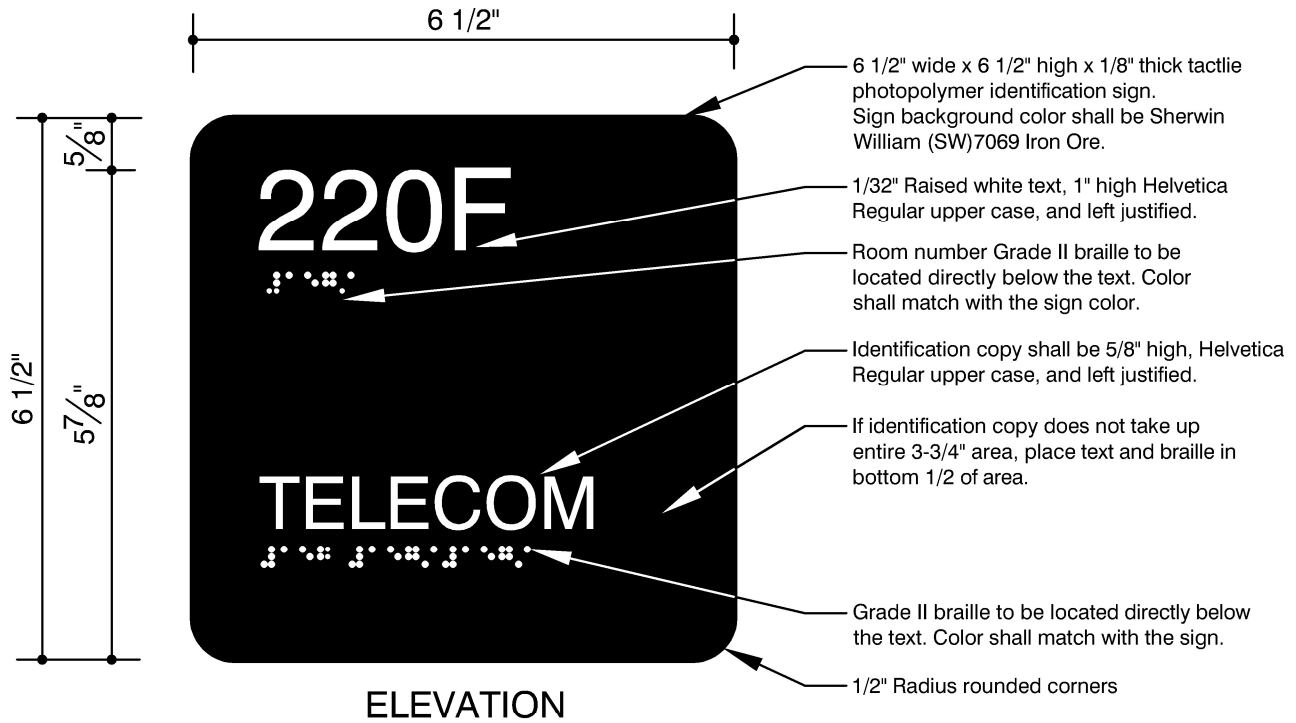

Requirements:

- Submit sample to ISU for approval.
- All signs to meet ADA requirements.
- Two strips of double sided 3 M VHB tape mounting to be included unless otherwise noted.

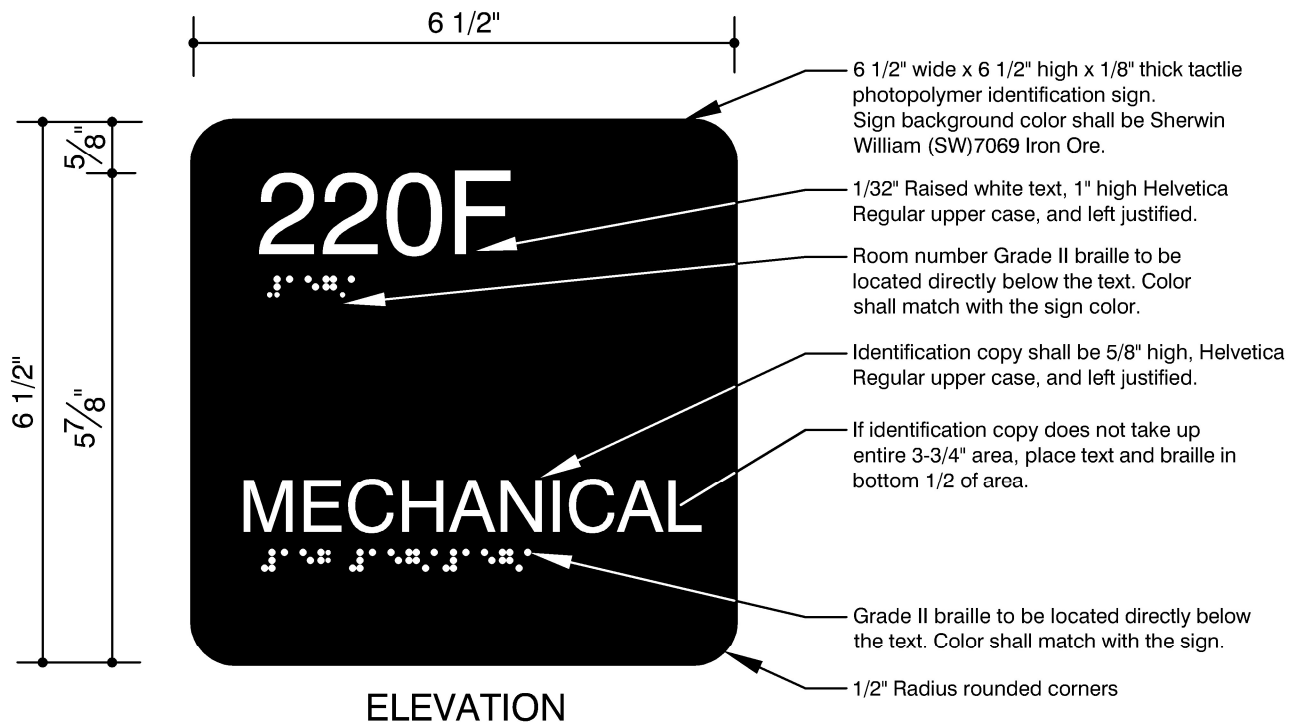

Requirements:

- Submit sample to ISU for approval.
- All signs to meet ADA requirements.
- Two strips of double sided 3 M VHB tape mounting to be included unless otherwise noted.

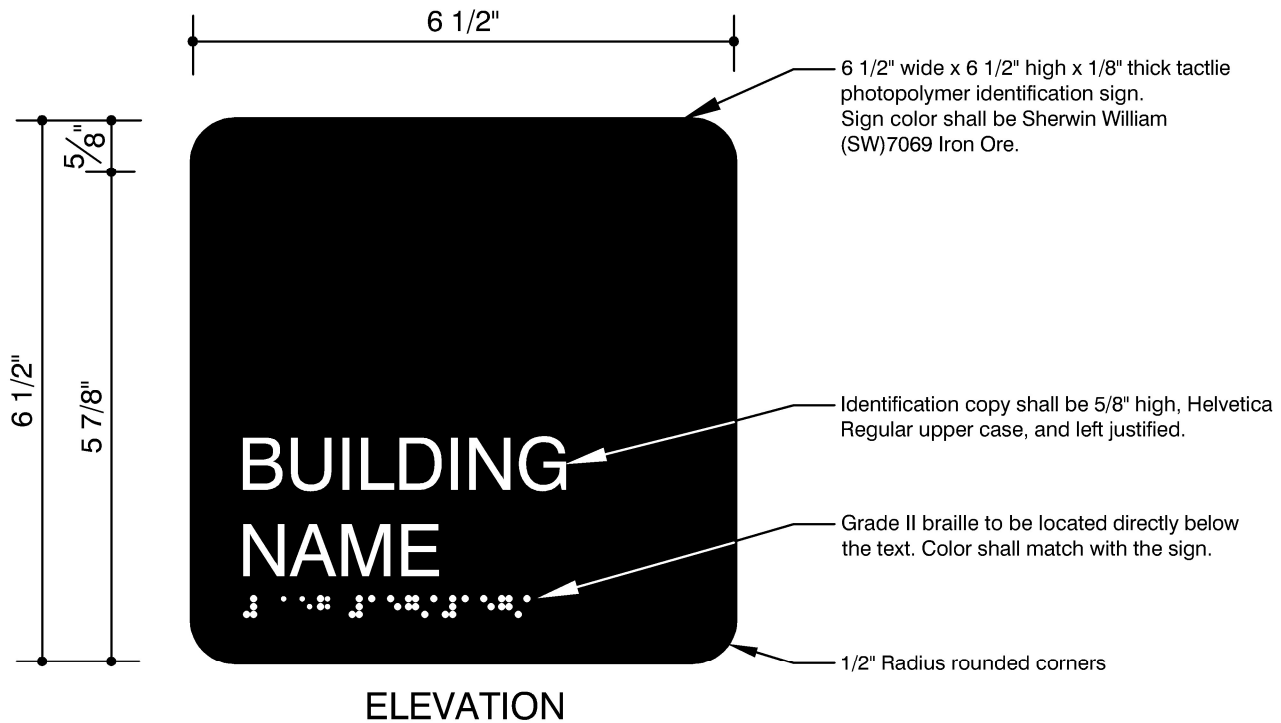

Requirements:

- Submit sample to ISU for approval.
- All signs to meet ADA requirements.
- Two strips of double sided 3 M VHB tape mounting to be included unless otherwise noted.

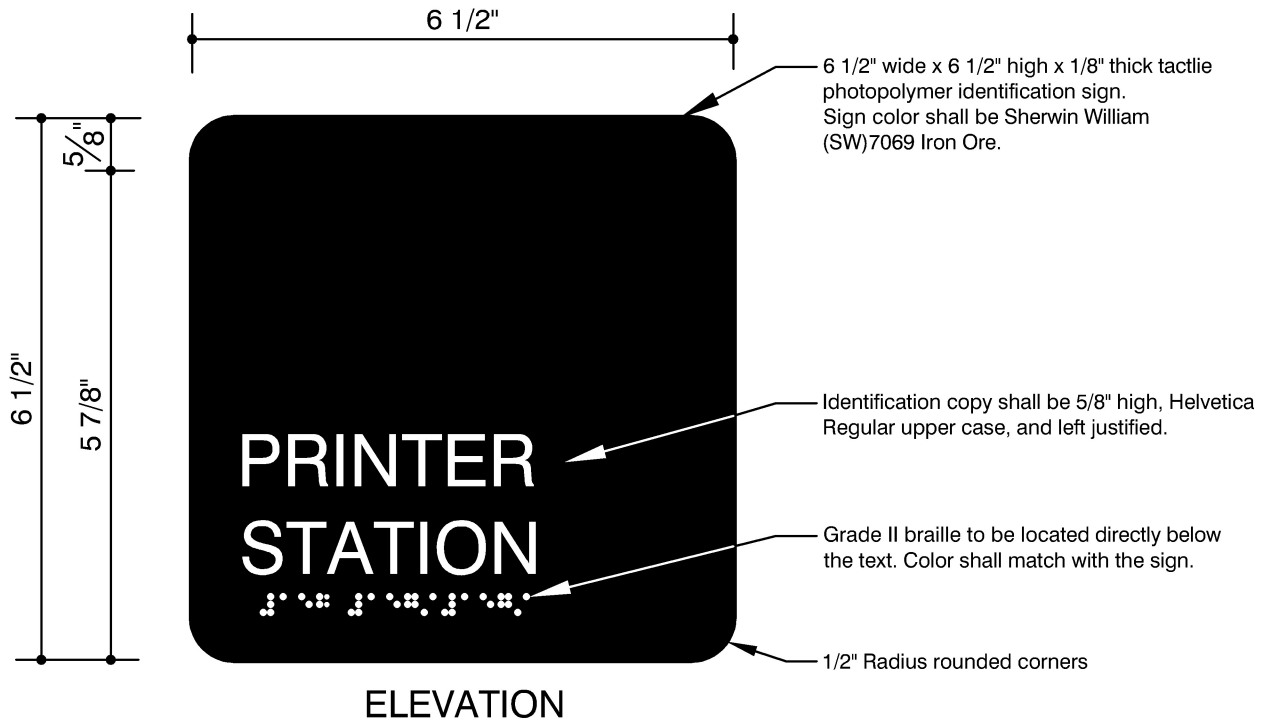

Requirements:

- Submit sample to ISU for approval.
- All signs to meet ADA requirements.
- Two strips of double sided 3 M VHB tape mounting to be included unless otherwise noted.

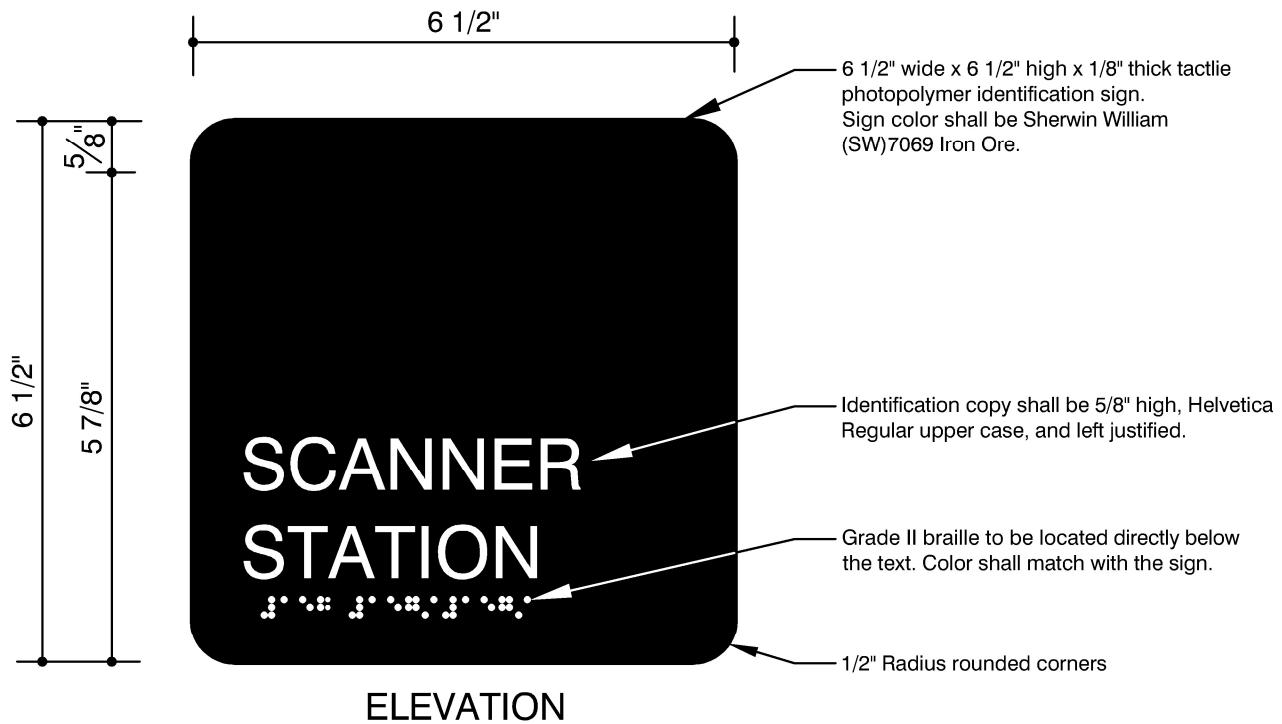

Requirements:

- Submit sample to ISU for approval.
- All signs to meet ADA requirements.
- Two strips of double sided 3 M VHB tape mounting to be included unless otherwise noted.

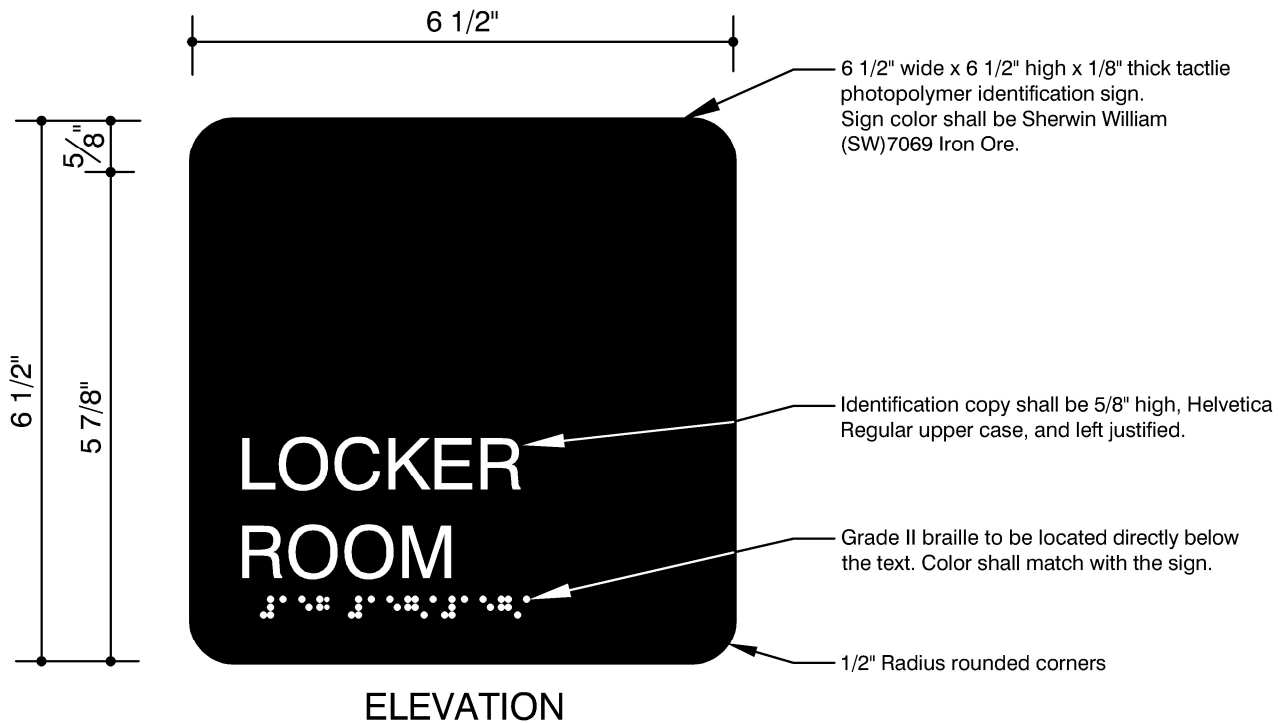

Requirements:

- Submit sample to ISU for approval.
- All signs to meet ADA requirements.
- Two strips of double sided 3 M VHB tape mounting to be included unless otherwise noted.

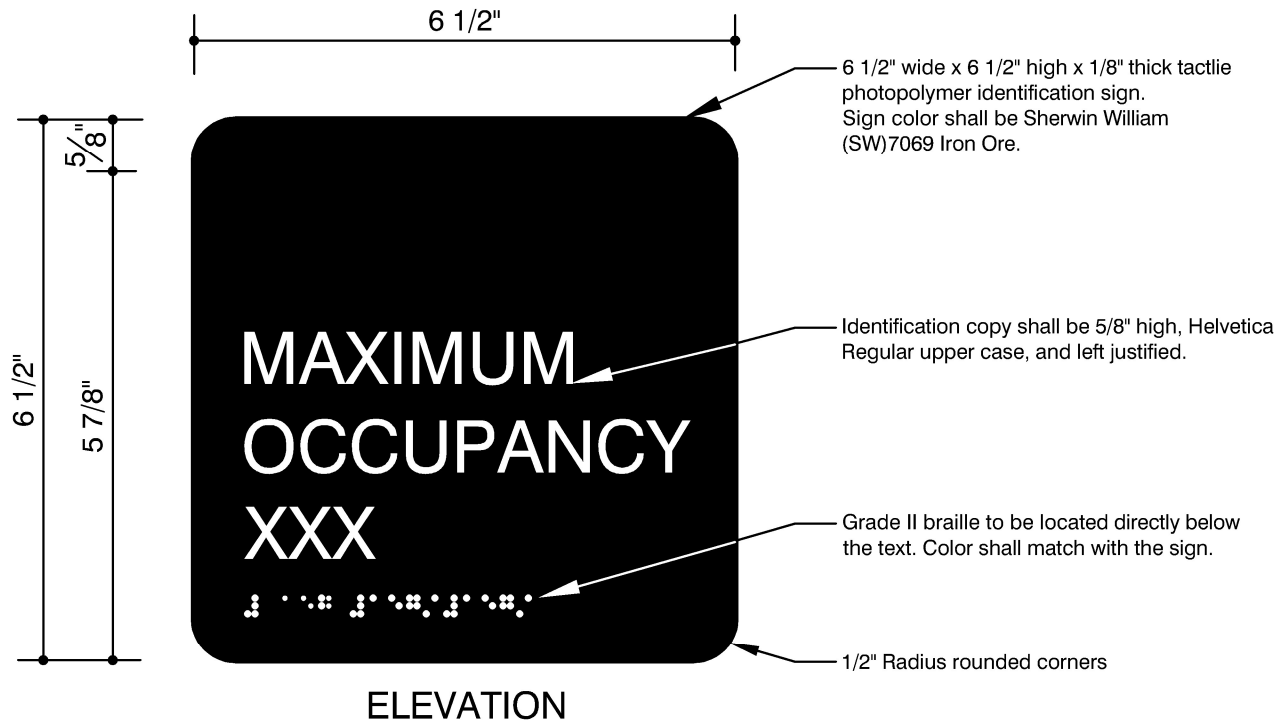

Requirements:

- Submit sample to ISU for approval.
- All signs to meet ADA requirements.
- Two strips of double sided 3 M VHB tape mounting to be included unless otherwise noted.

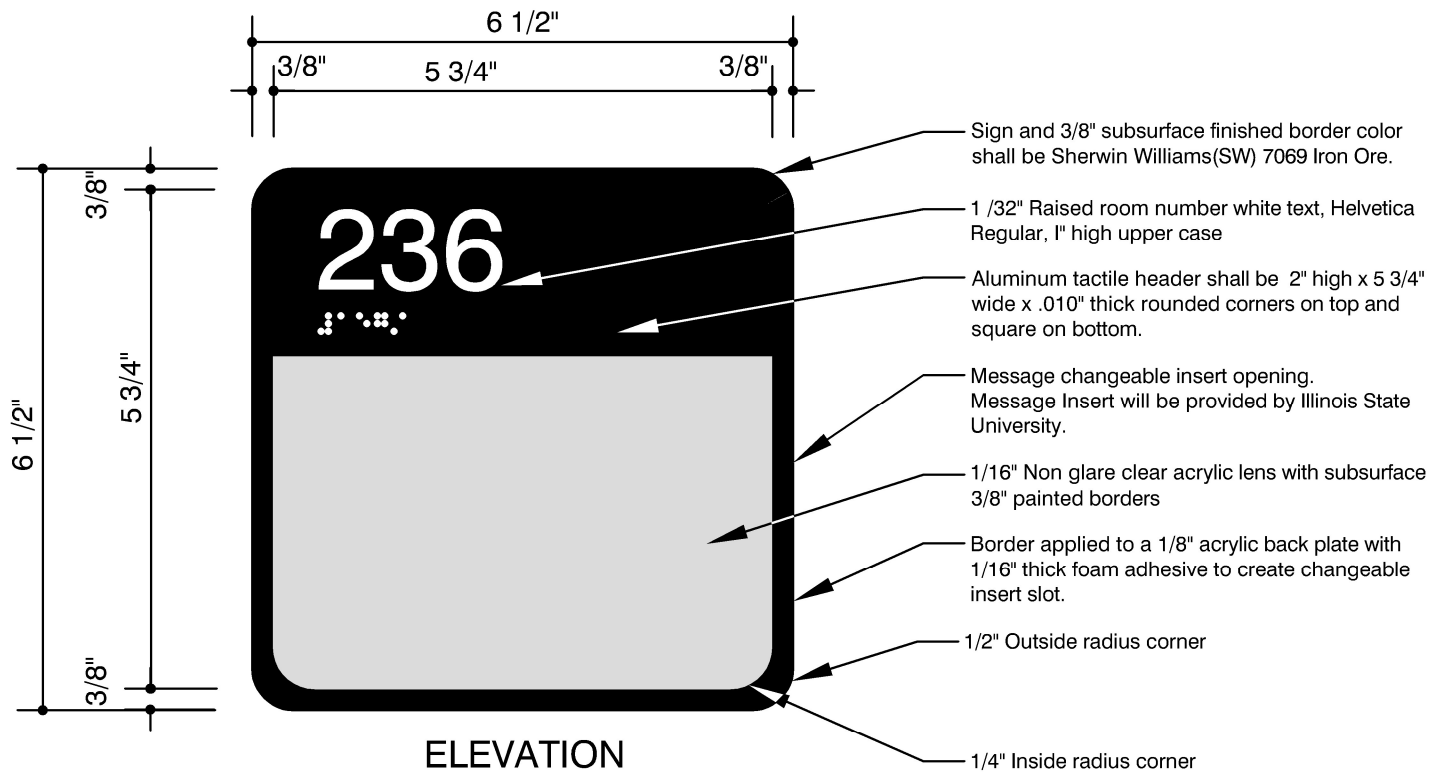

Requirements:

- Submit sample to ISU for approval.
- All signs to meet ADA requirements.
- Two strips of double sided 3 M VHB tape mounting to be included unless otherwise noted.

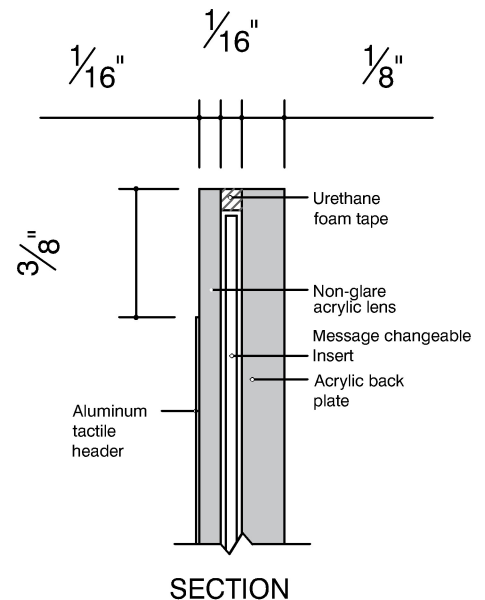

8 1/2" Wide

ISU Sign Standards

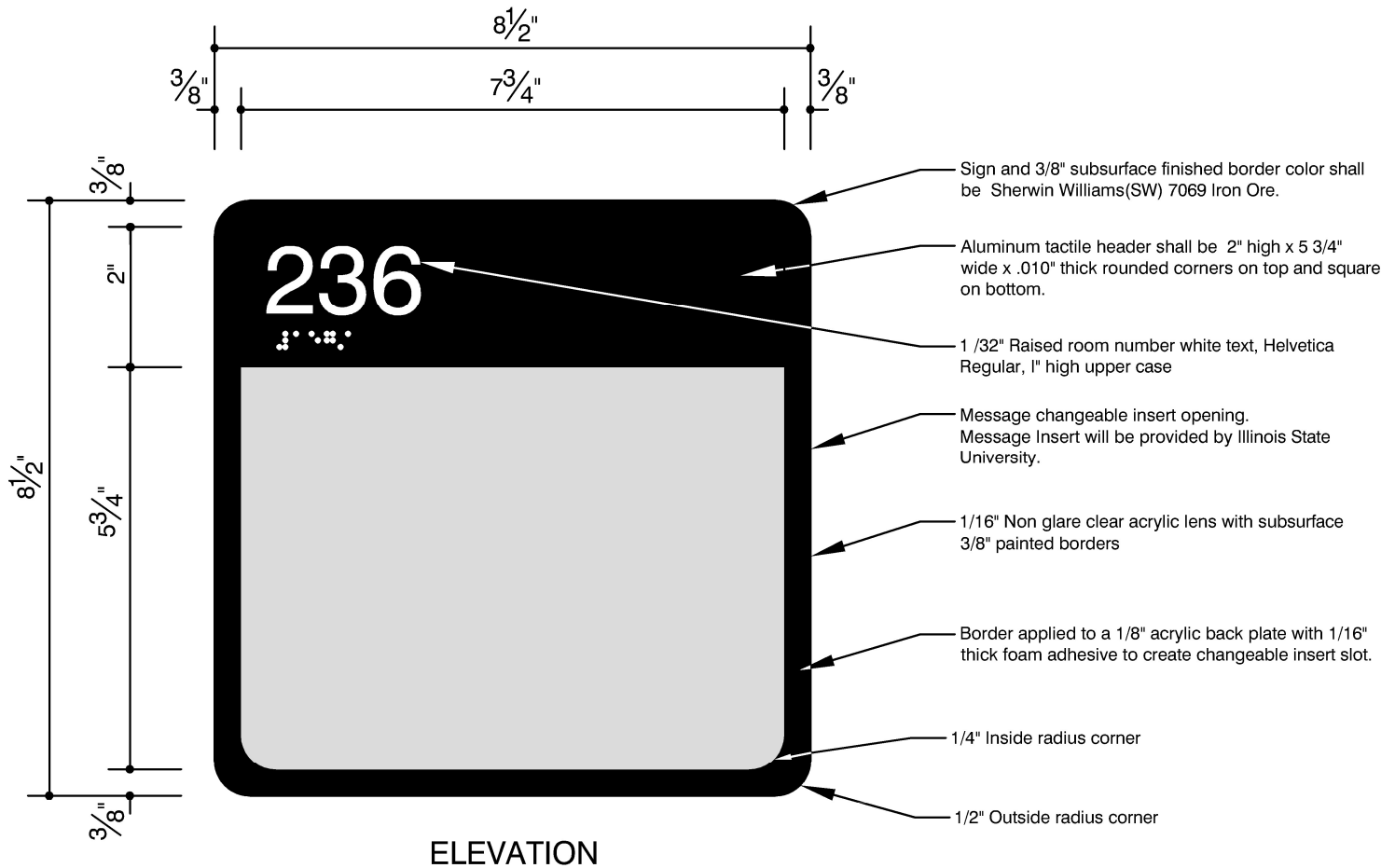

Requirements:

- Submit sample to ISU for approval.
- All signs shall meet ADA requirements.
- Two strips of double sided foam tape mounting shall be included unless otherwise noted.

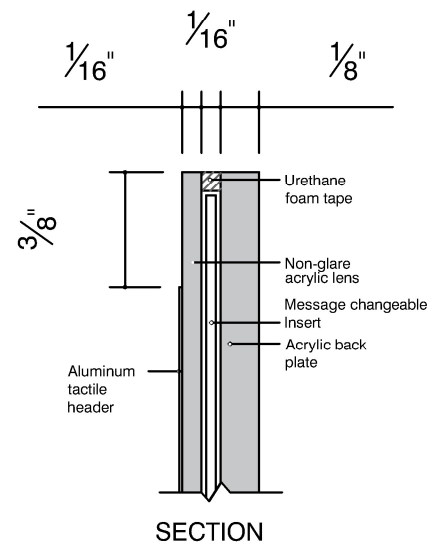

Room Identification - Insert Name - 8 1/2" Wide - Arrow

ID-3.2

ISU Sign Standards

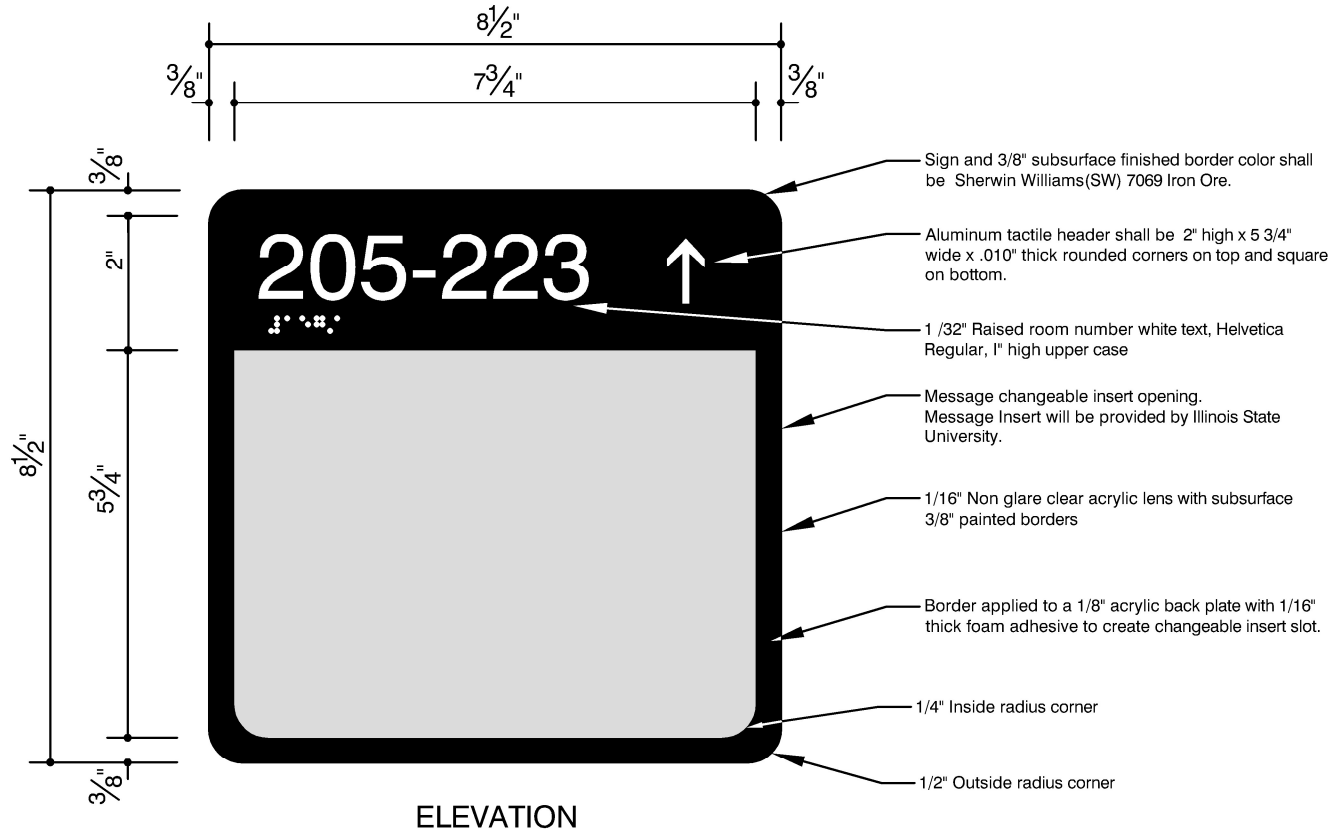

Requirements:

- Submit sample to ISU for approval.
- All signs to meet ADA requirements.
- Two strips of double sided 3 M VHB tape mounting to be included unless otherwise noted.

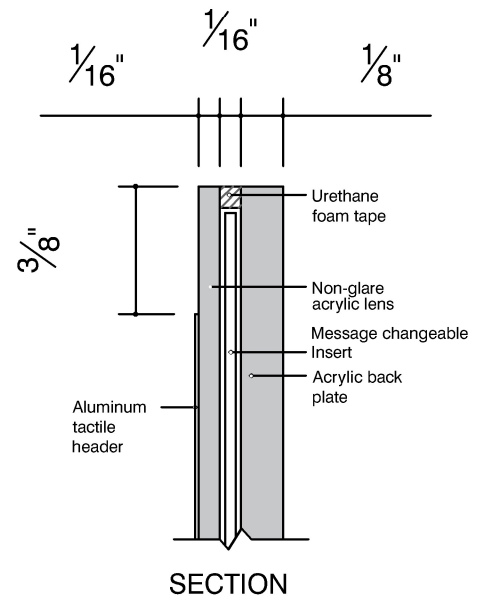

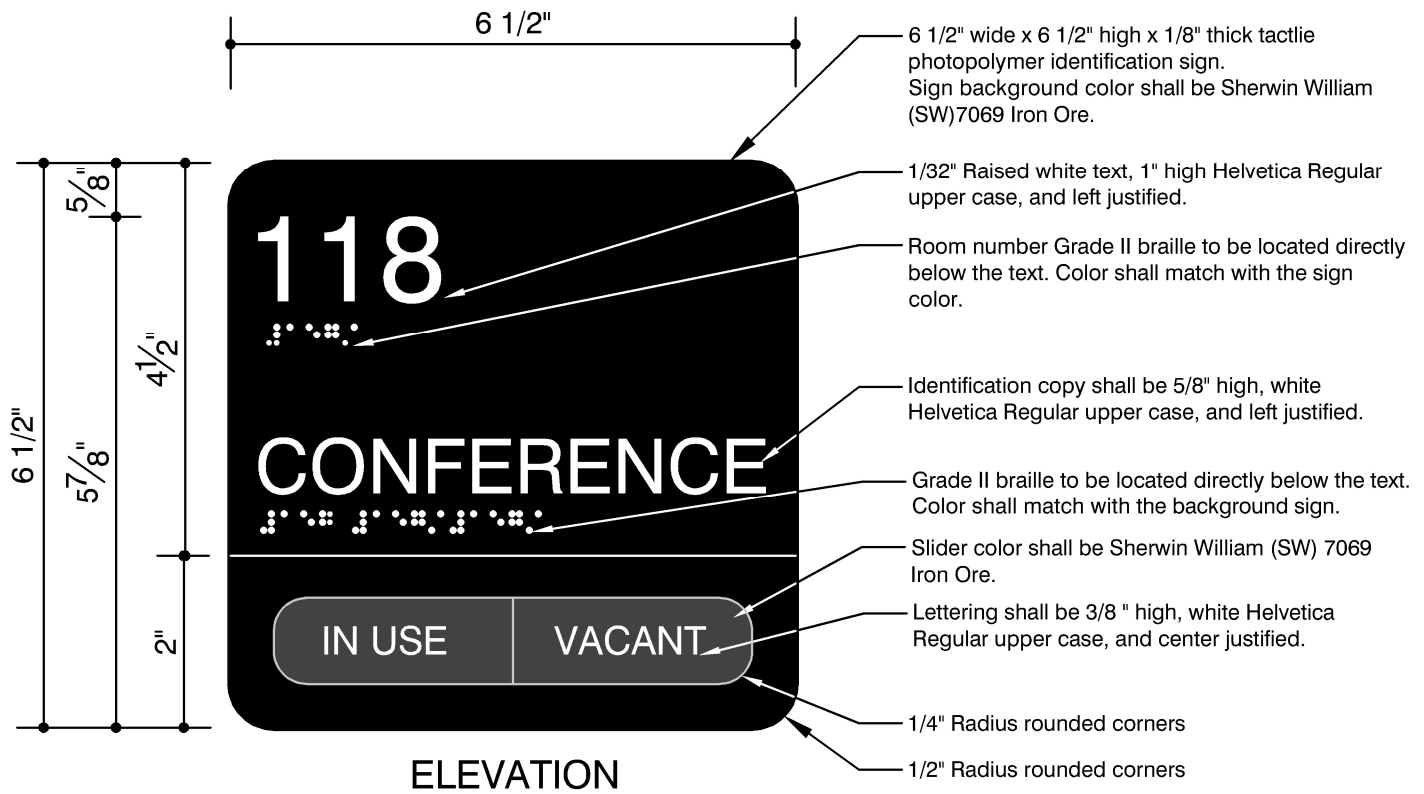

Requirements:

- Submit sample to ISU for approval.
- All signs shall meet ADA requirements.
- Two strips of double sided 3 M VHB tape mounting to be included unless otherwise noted.

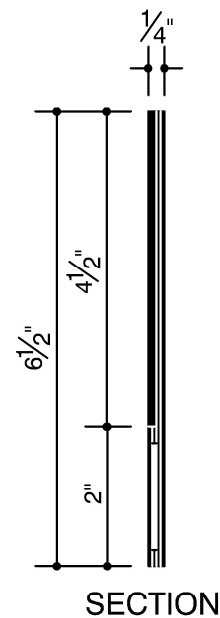

Restroom Identification - Accessible - Women

RR-1

ISU Sign Standards

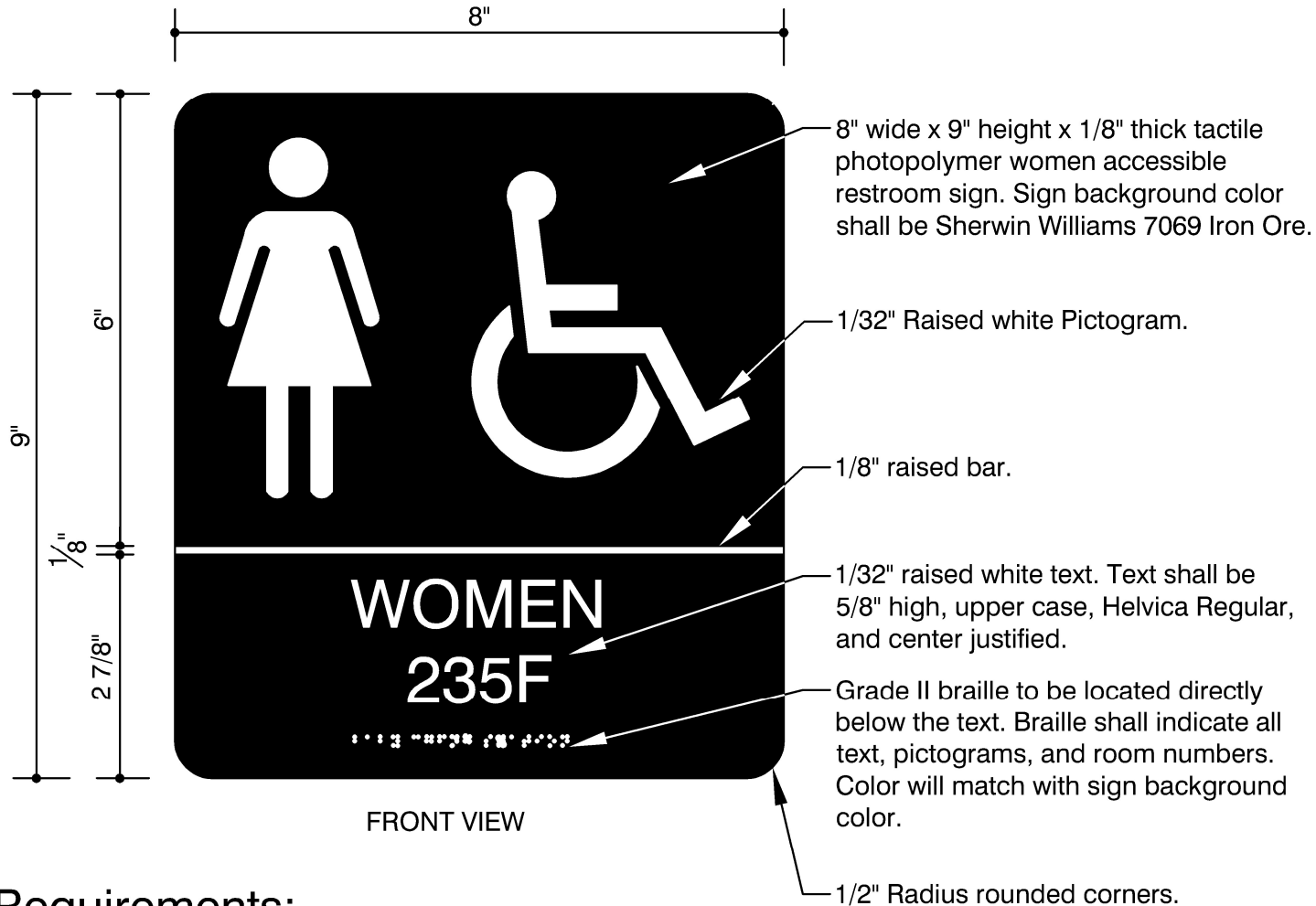

Requirements:

- Submit sample to ISU for approval.
- All signs to meet ADA requirements.
- Two strips of double sided 3 M VHB tape mounting to be included unless otherwise noted.

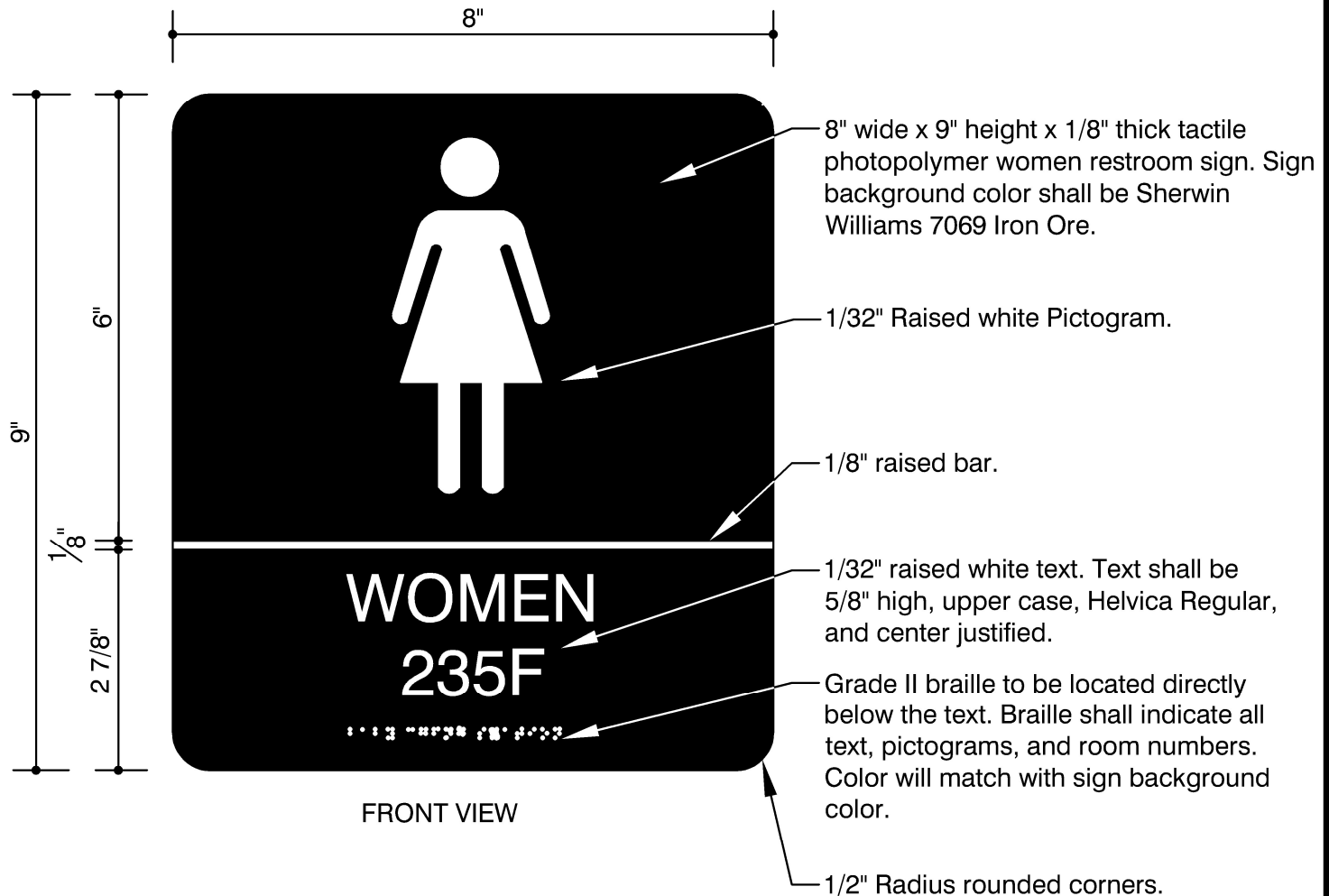

Requirements:

- Submit sample to ISU for approval.
- All signs to meet ADA requirements.
- Two strips of double sided 3 M VHB tape mounting to be included unless otherwise noted.

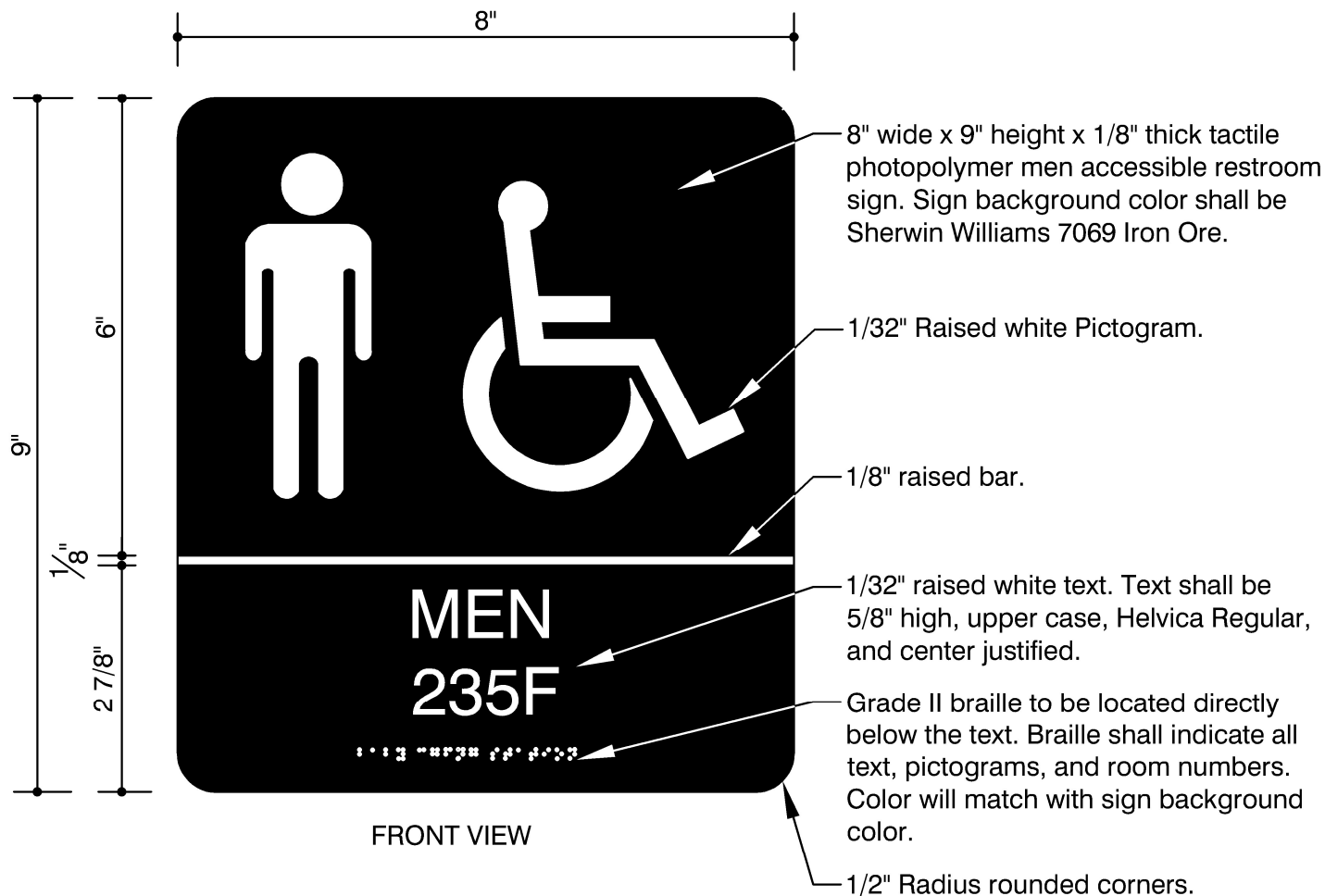

Requirements:

- Submit sample to ISU for approval.
- All signs to meet ADA requirements.
- Two strips of double sided 3 M VHB tape mounting to be included unless otherwise noted.

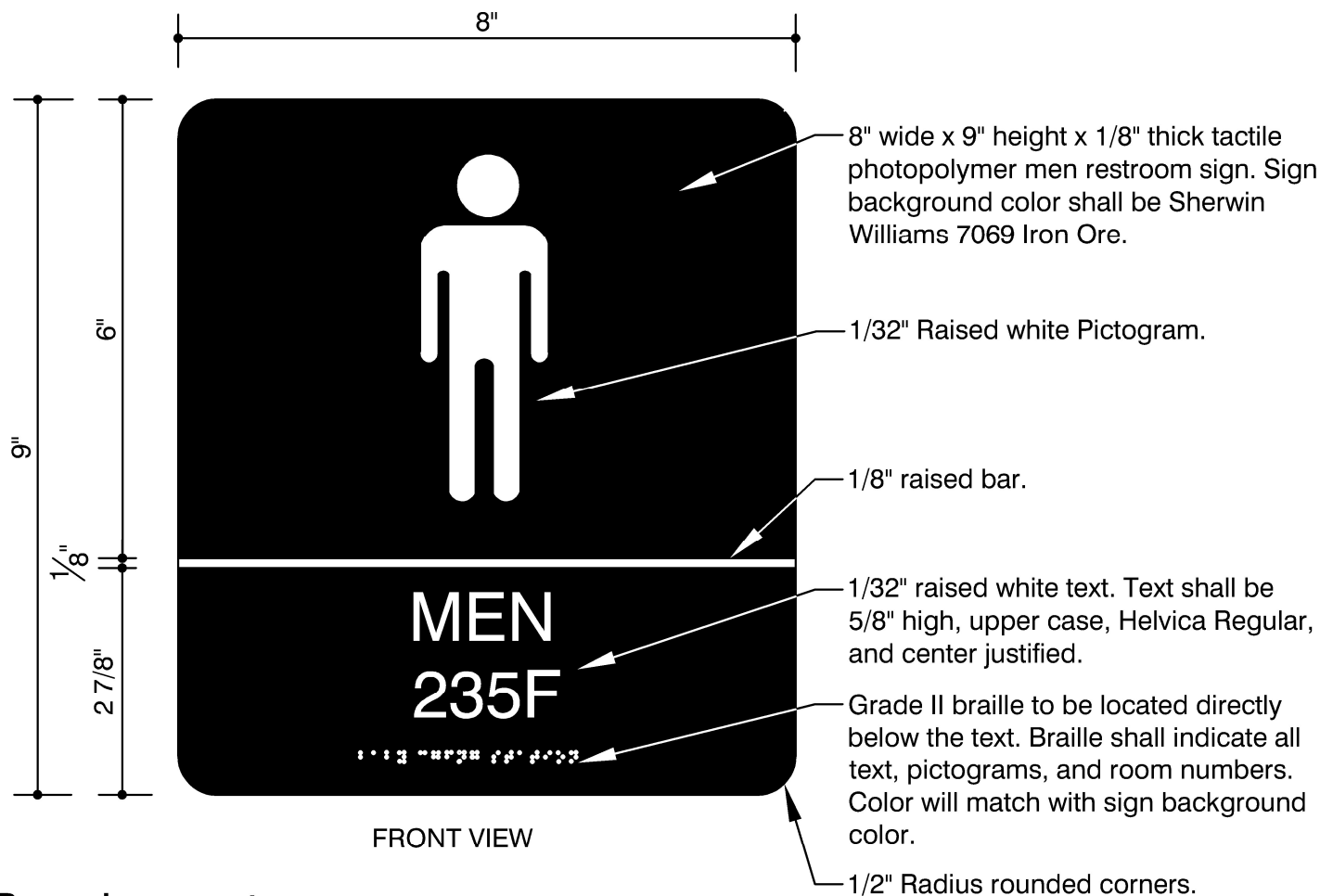

Requirements:

- Submit sample to ISU for approval.
- All signs to meet ADA requirements.
- Two strips of double sided 3 M VHB tape mounting to be included unless otherwise noted.

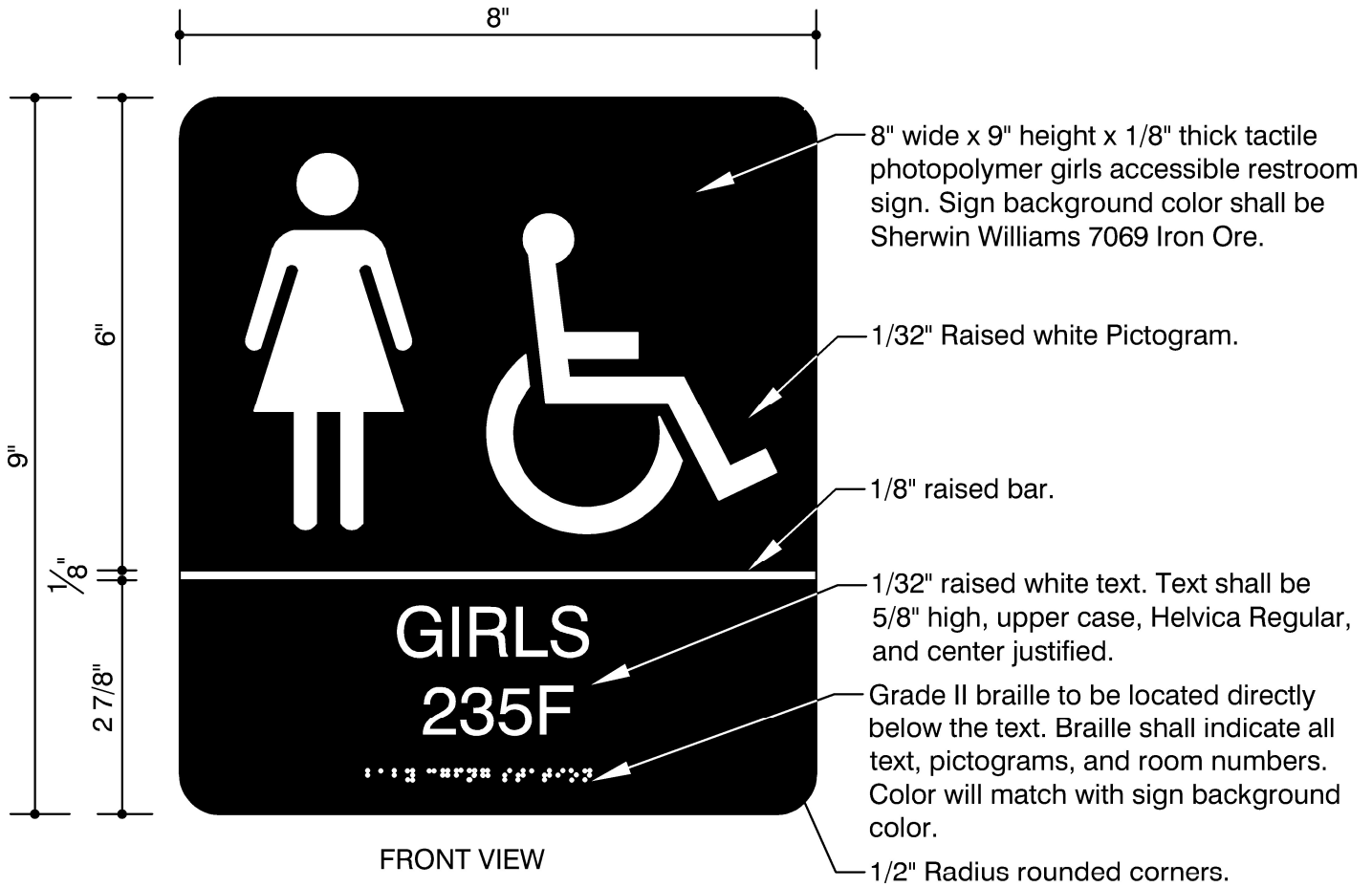

Requirements:

- Submit sample to ISU for approval.
- All signs to meet ADA requirements.
- Two strips of double sided 3 M VHB tape mounting to be included unless otherwise noted.

Restroom Identification - Girls

RR-3.1

ISU Sign Standards

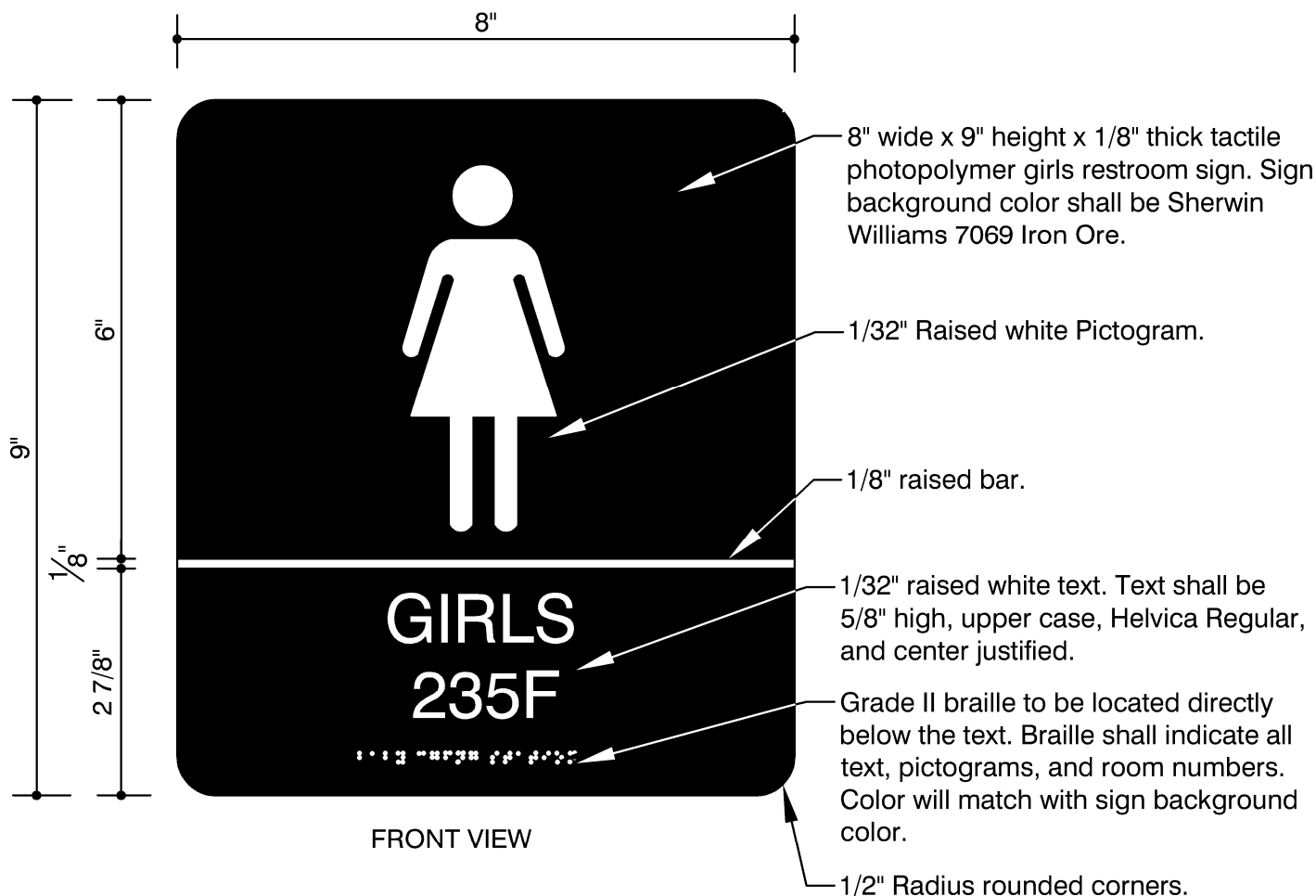

Requirements:

- Submit sample to ISU for approval.
- All signs to meet ADA requirements.
- Two strips of double sided 3 M VHB tape mounting to be included unless otherwise noted.

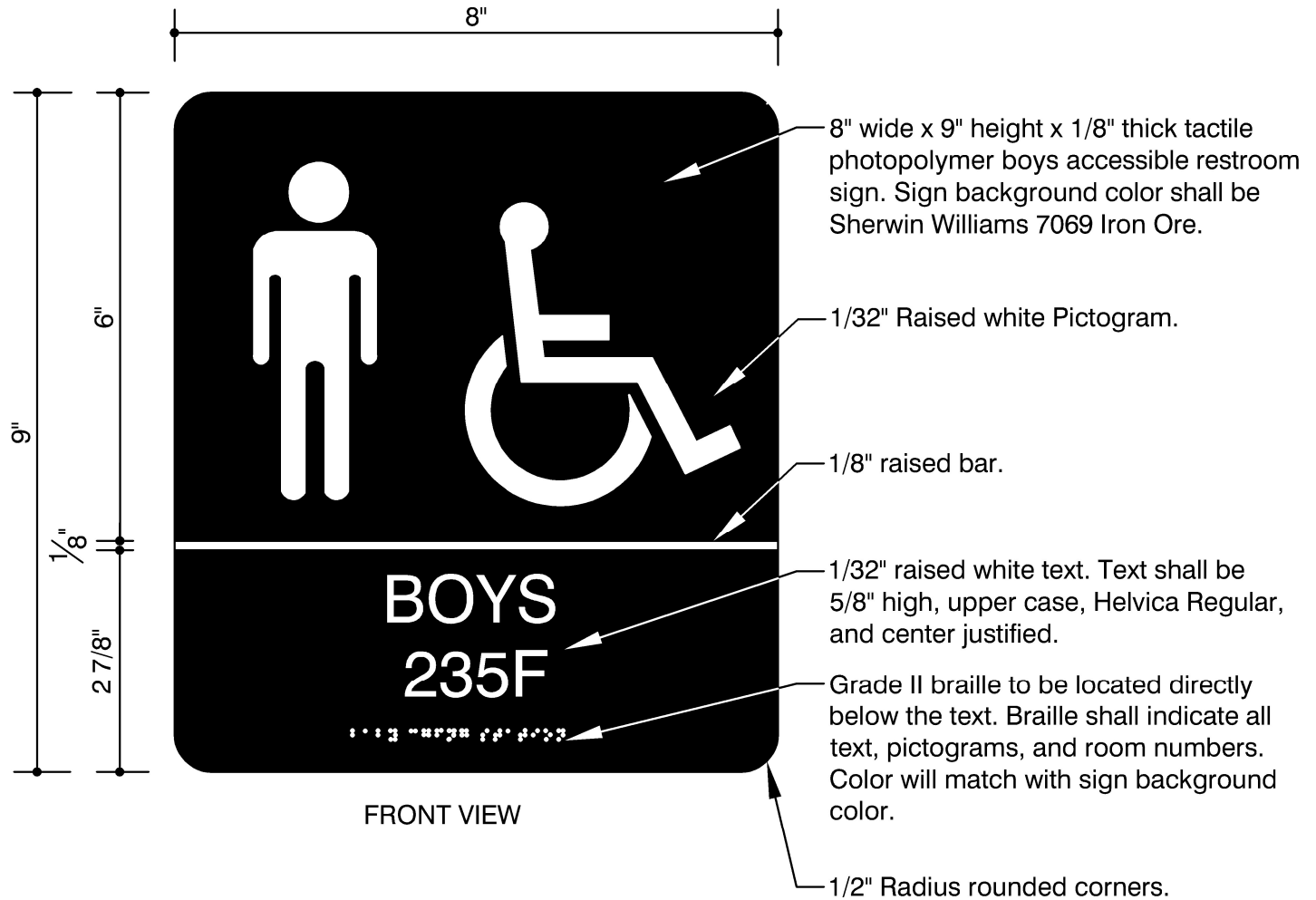

Requirements:

- Submit sample to ISU for approval.
- All signs to meet ADA requirements.
- Two strips of double sided 3 M VHB tape mounting to be included unless otherwise noted.

Restroom Identification - Boys

RR-4.1

ISU Sign Standards

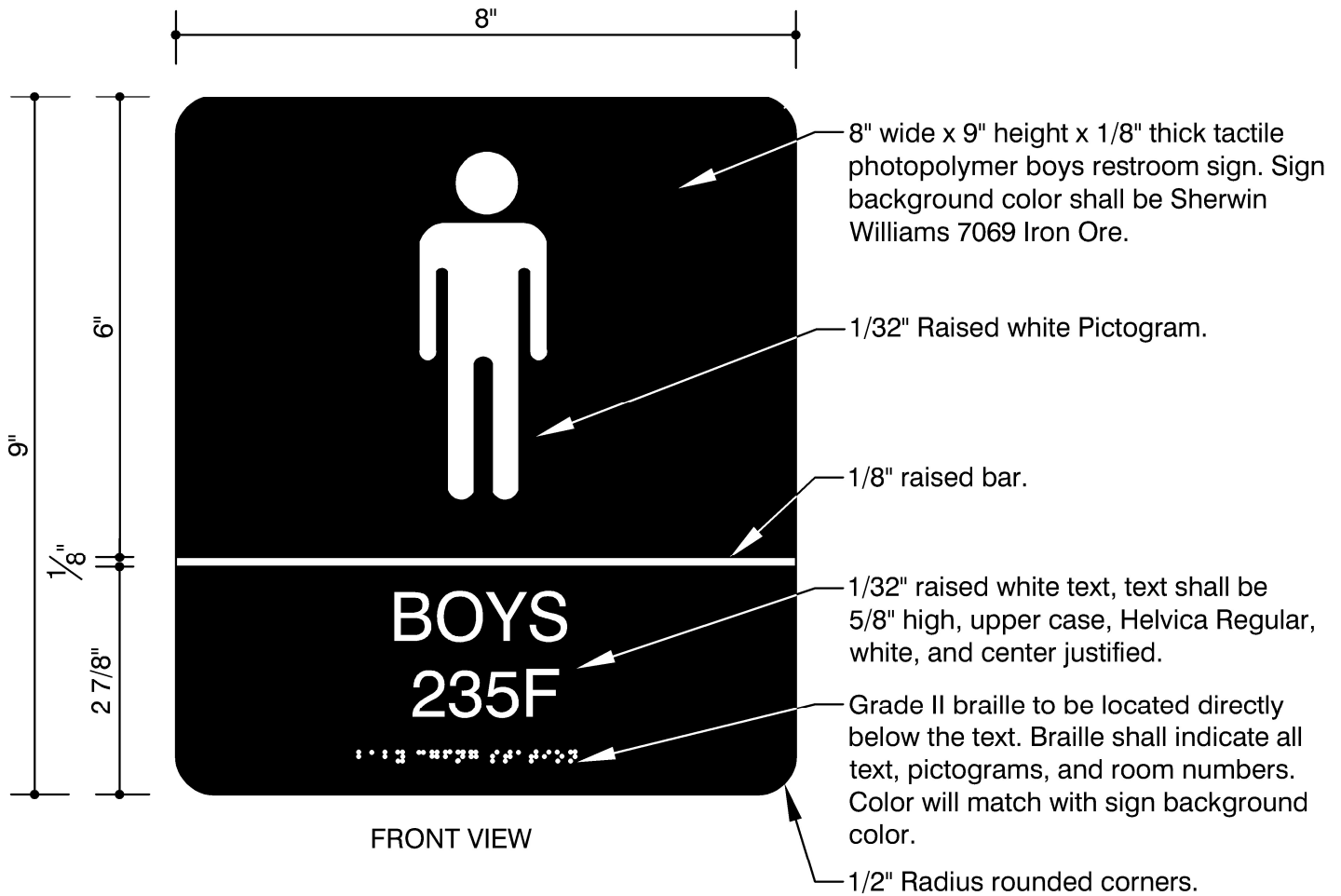

Requirements:

- Submit sample to ISU for approval.
- All signs to meet ADA requirements.
- Two strips of double sided 3 M VHB tape mounting to be included unless otherwise noted.

Restroom Identification - Accessible - All Gender

RR-5

ISU Sign Standards



Requirements:

- Submit sample to ISU for approval.
- All signs to meet ADA requirements.
- Two strips of double sided 3 M VHB tape mounting to be included unless otherwise noted.

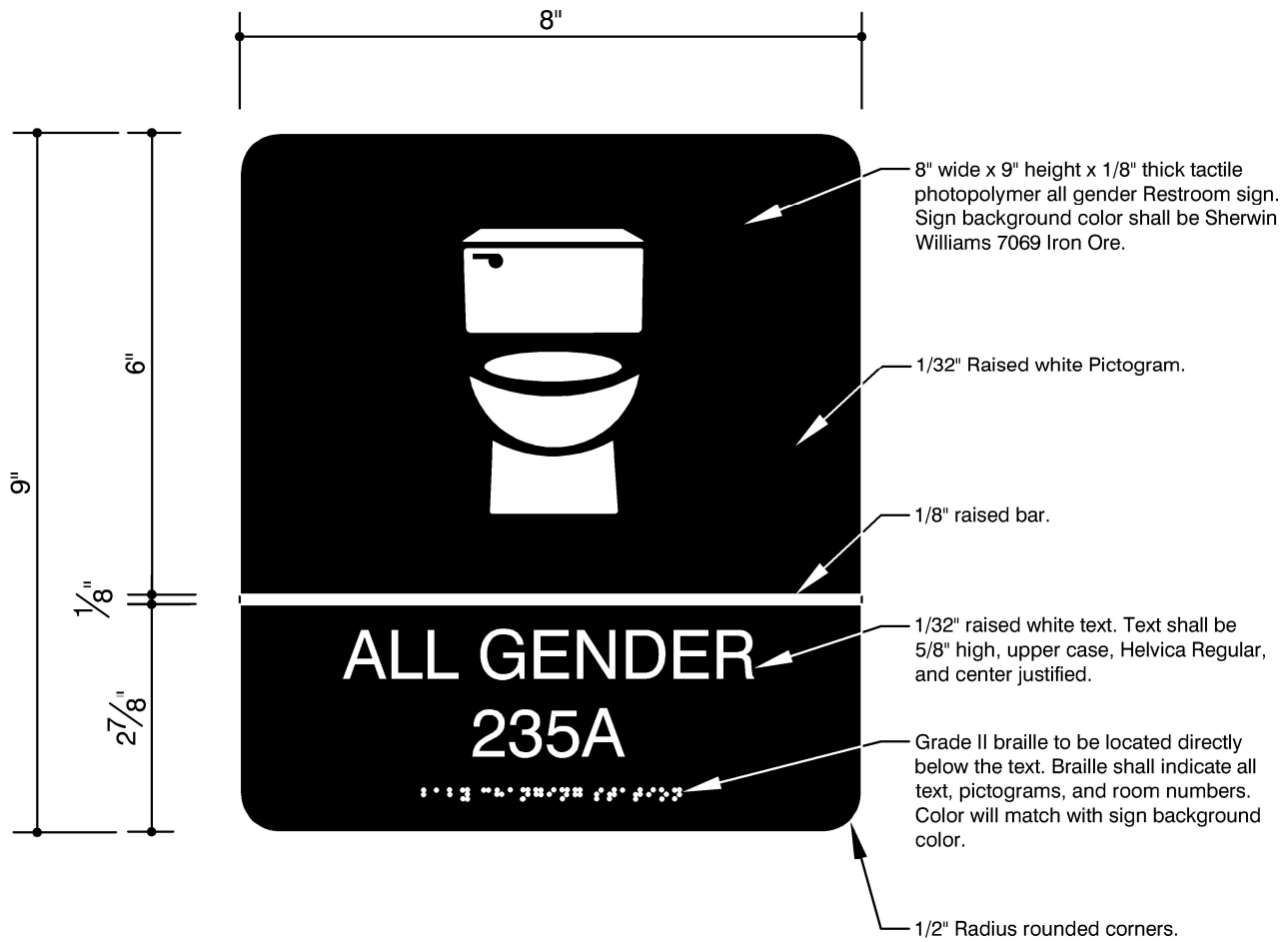

Requirements:

- Submit sample to ISU for approval.
- All signs to meet ADA requirements.
- Two strips of double sided 3 M VHB tape mounting to be included unless otherwise noted.

Restroom Identification - Accessible Baby Changing Station - Women

RR-6

ISU Sign Standards

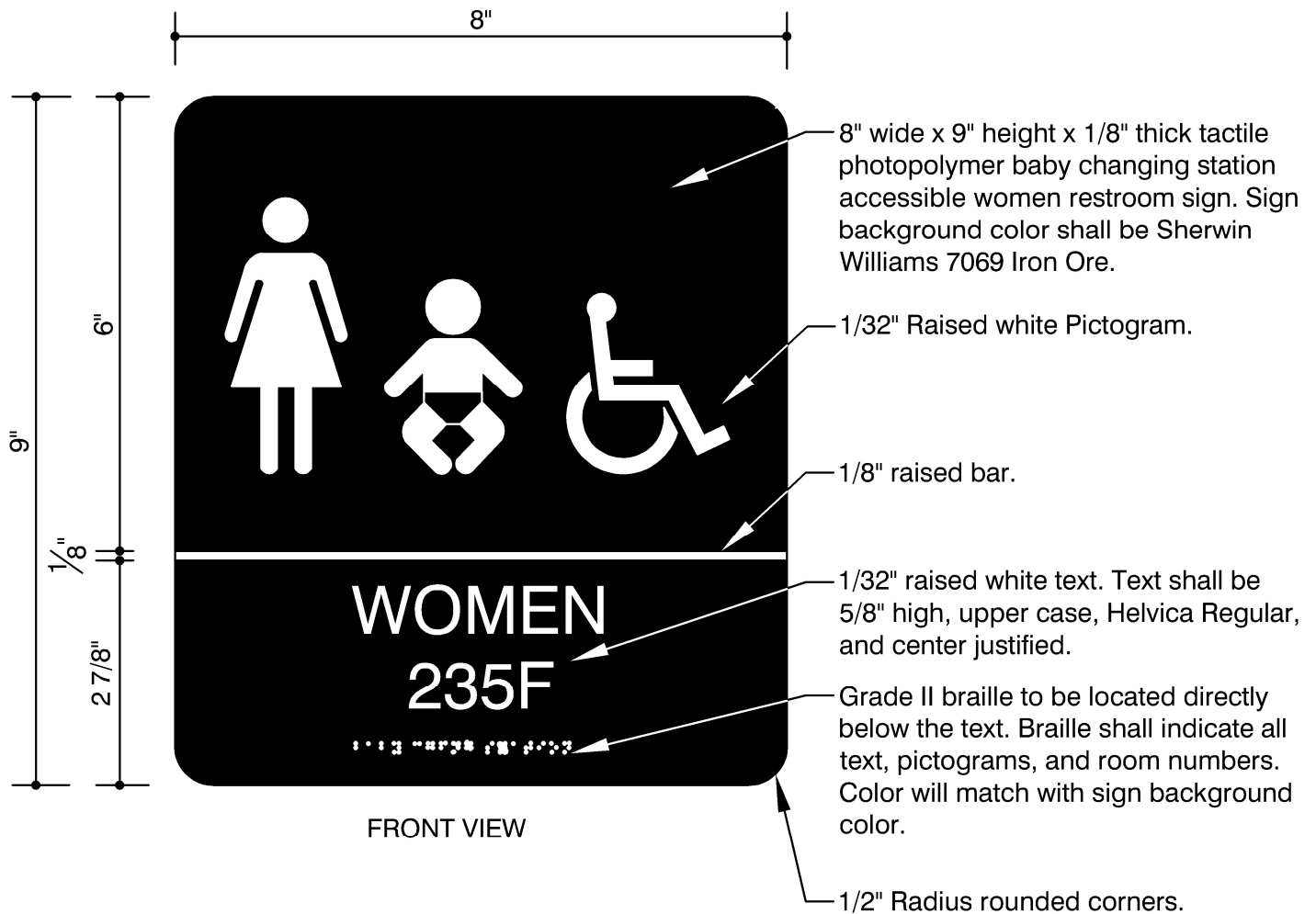

Requirements:

- Submit sample to ISU for approval.
- All signs to meet ADA requirements.
- Two strips of double sided 3 M VHB tape mounting to be included unless otherwise noted.

Restroom Identification - Baby Changing Station - Women

RR-6.1

ISU Sign Standards

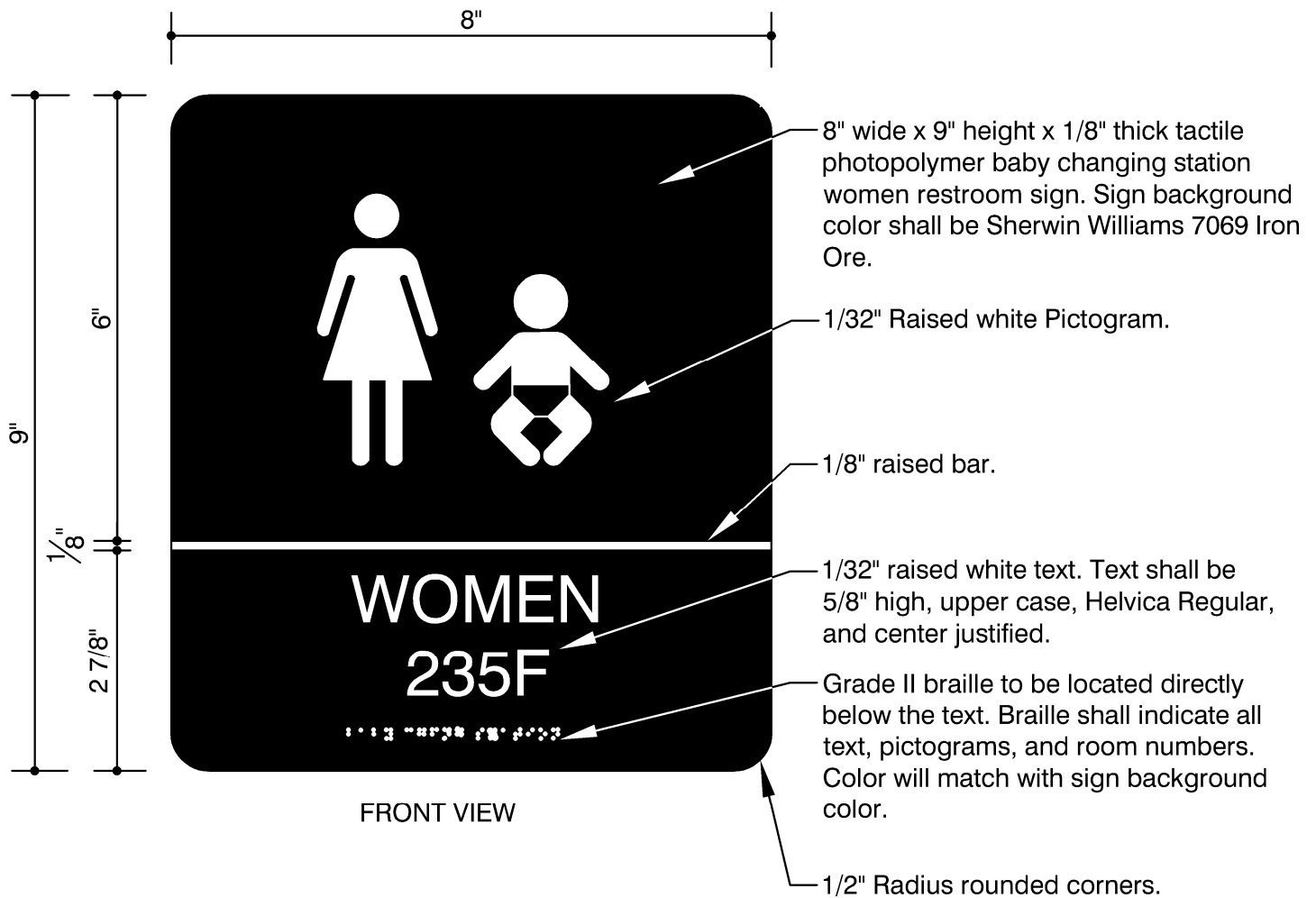

Requirements:

- Submit sample to ISU for approval.
- All signs to meet ADA requirements.
- Two strips of double sided 3 M VHB tape mounting to be included unless otherwise noted.

Restroom Identification - Accessible Baby Changing Station - Men

RR-7

ISU Sign Standards

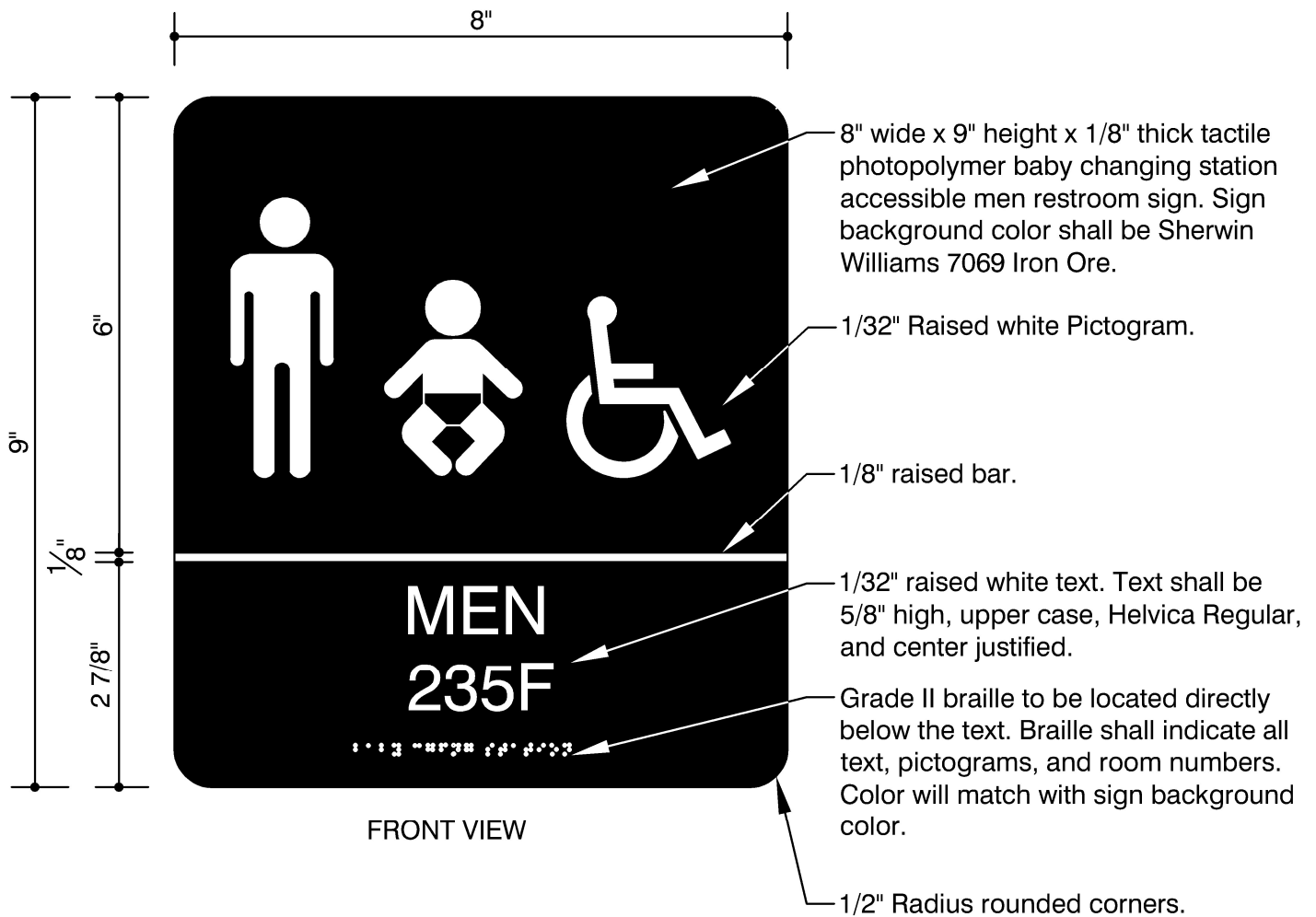

Requirements:

- Submit sample to ISU for approval.
- All signs to meet ADA requirements.
- Two strips of double sided 3 M VHB tape mounting to be included unless otherwise noted.

Restroom Identification - Baby Changing Station - Men

RR-7.1

ISU Sign Standards

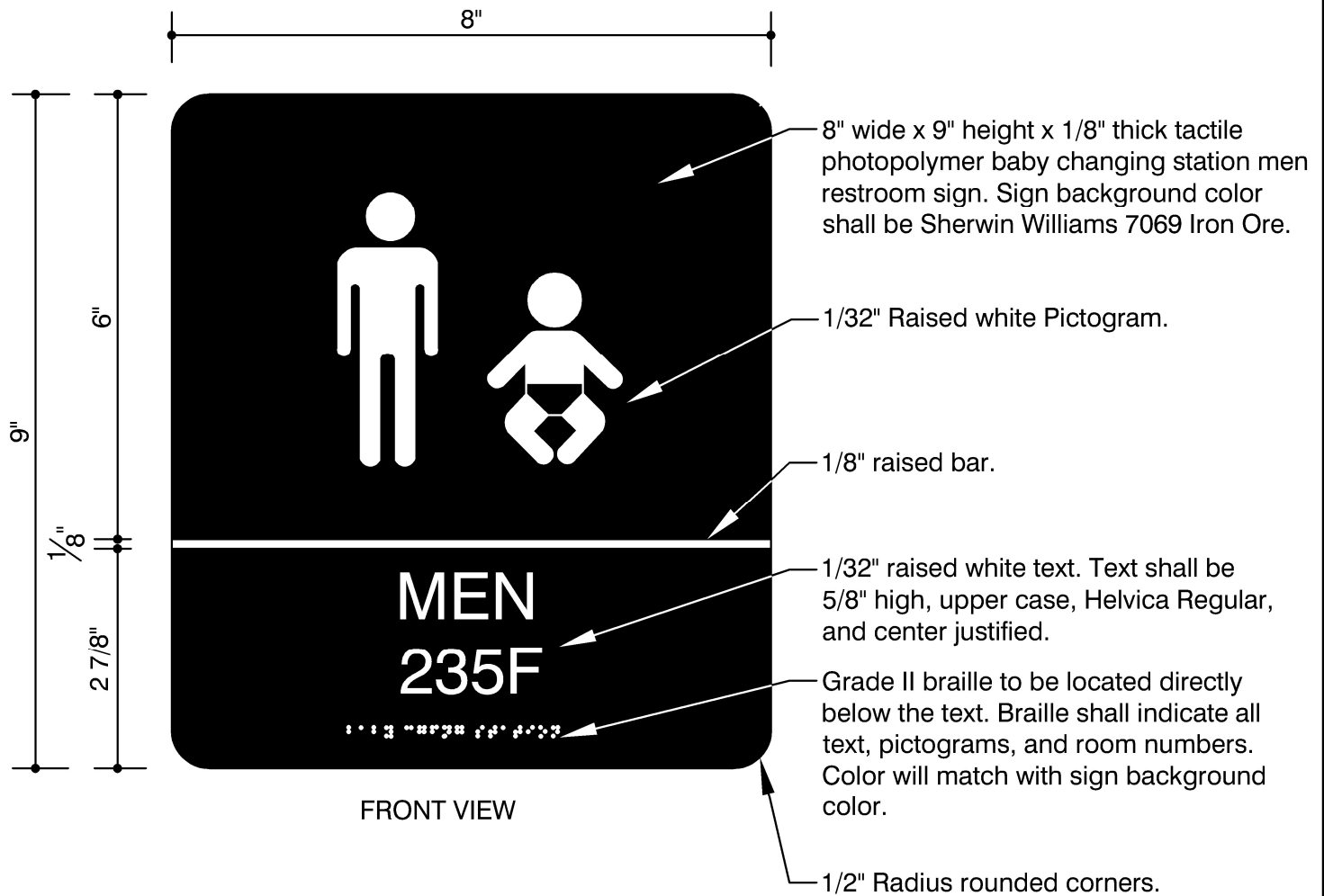

Requirements:

- Submit sample to ISU for approval.
- All signs to meet ADA requirements.
- Two strips of double sided 3 M VHB tape mounting to be included unless otherwise noted.

Restroom Identification - Accessible - Baby Changing Station - All Gender

RR-8

ISU Sign Standards

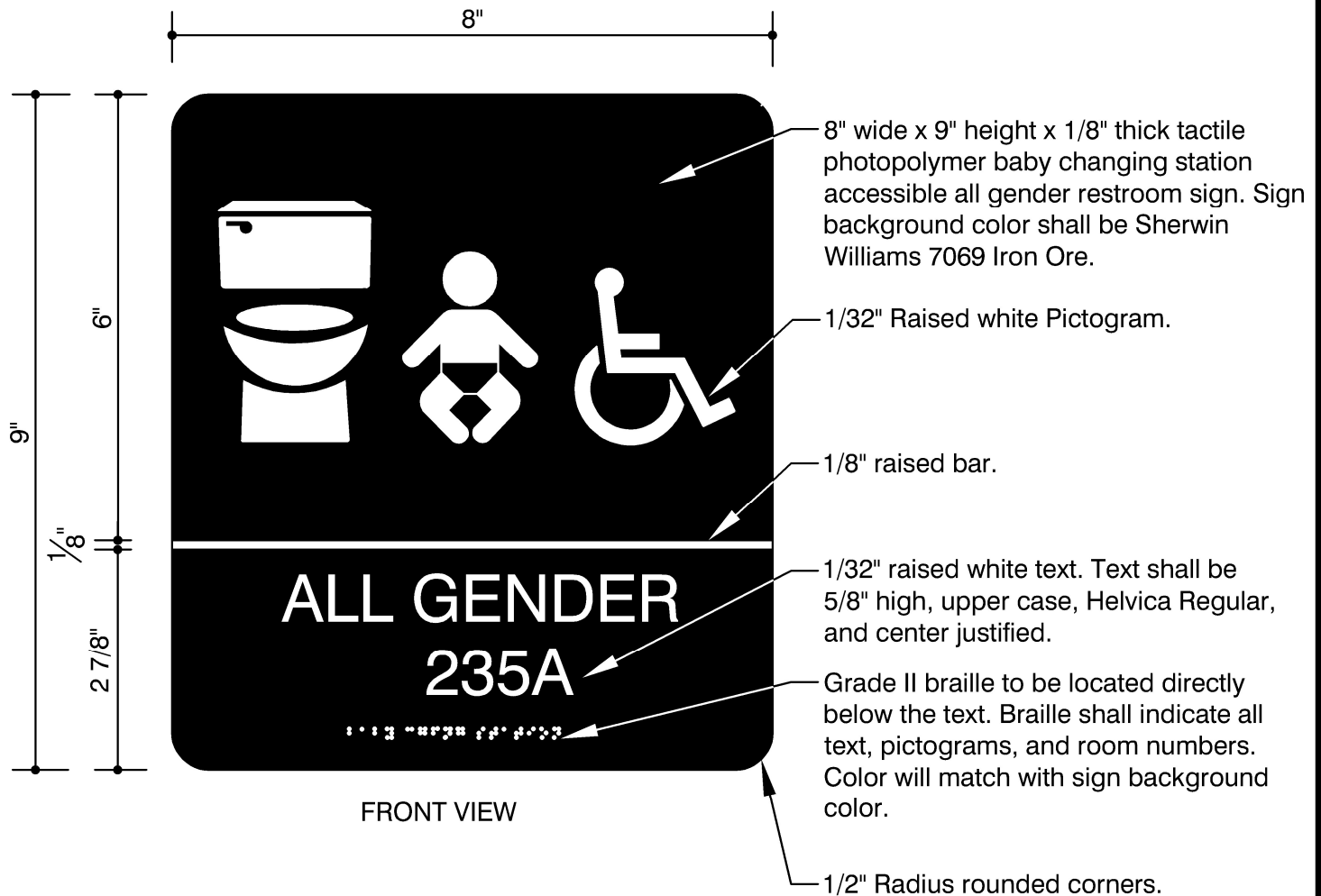

Requirements:

- Submit sample to ISU for approval.
- All signs to meet ADA requirements.
- Two strips of double sided 3 M VHB tape mounting to be included unless otherwise noted.

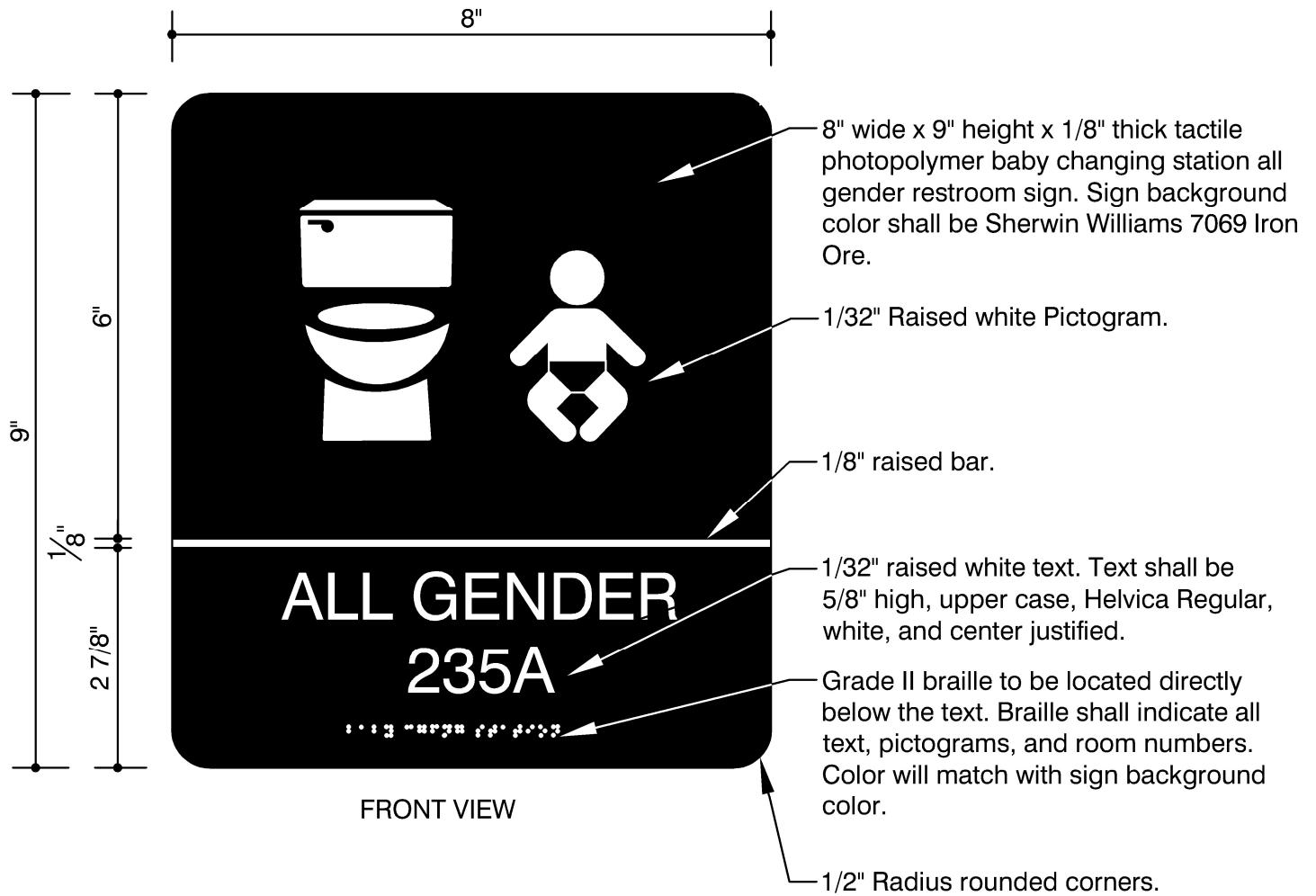

Requirements:

- Submit sample to ISU for approval.
- All signs to meet ADA requirements.
- Two strips of double sided 3 M VHB tape mounting to be included unless otherwise noted.

Wayfinding - Wall Mounted Sign - Portrait

W-1

ISU Sign Standards

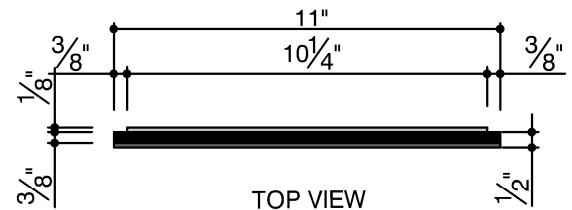
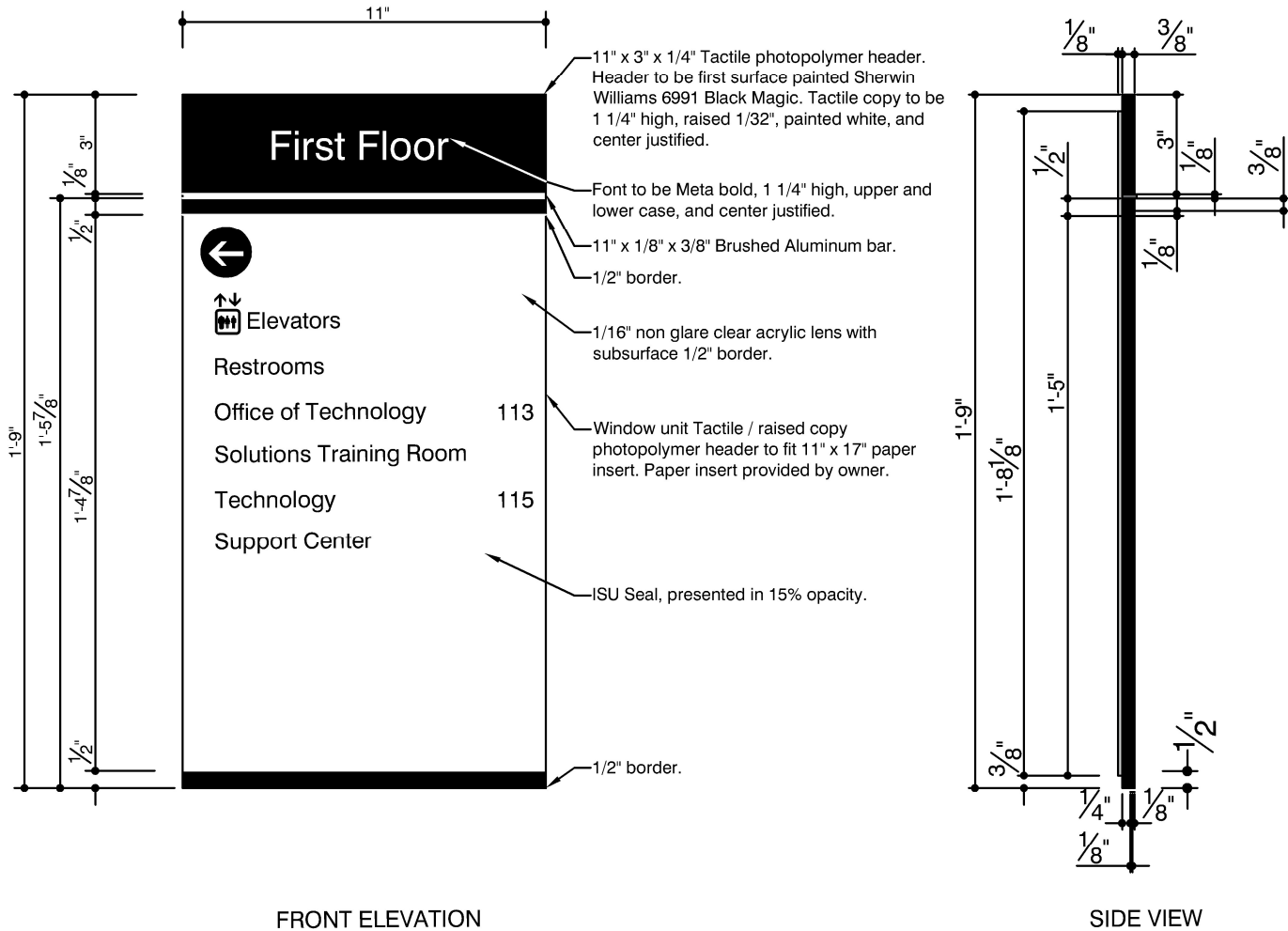

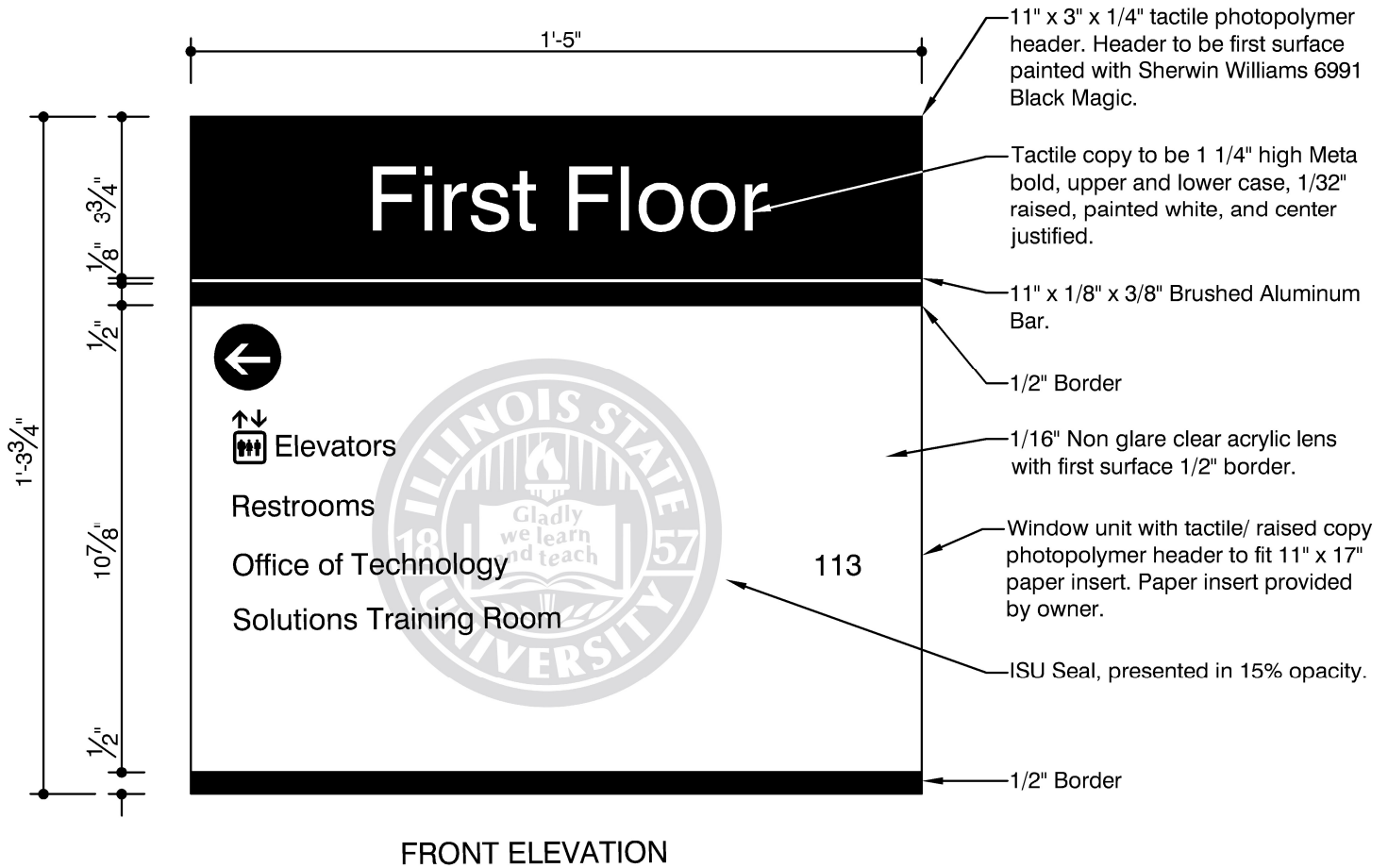

Wayfinding - Flag Sign - Accessible - Women

W-2

ISU Sign Standards

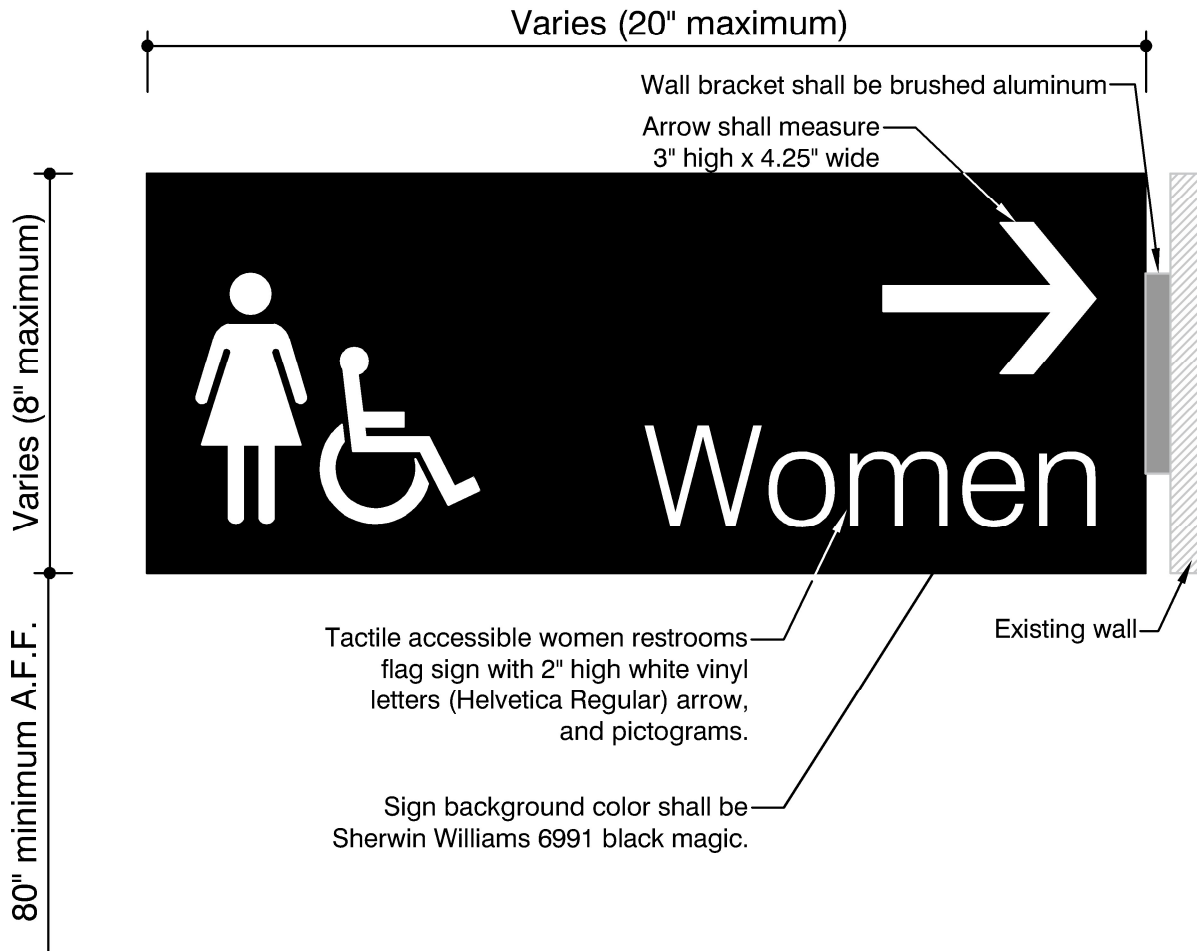

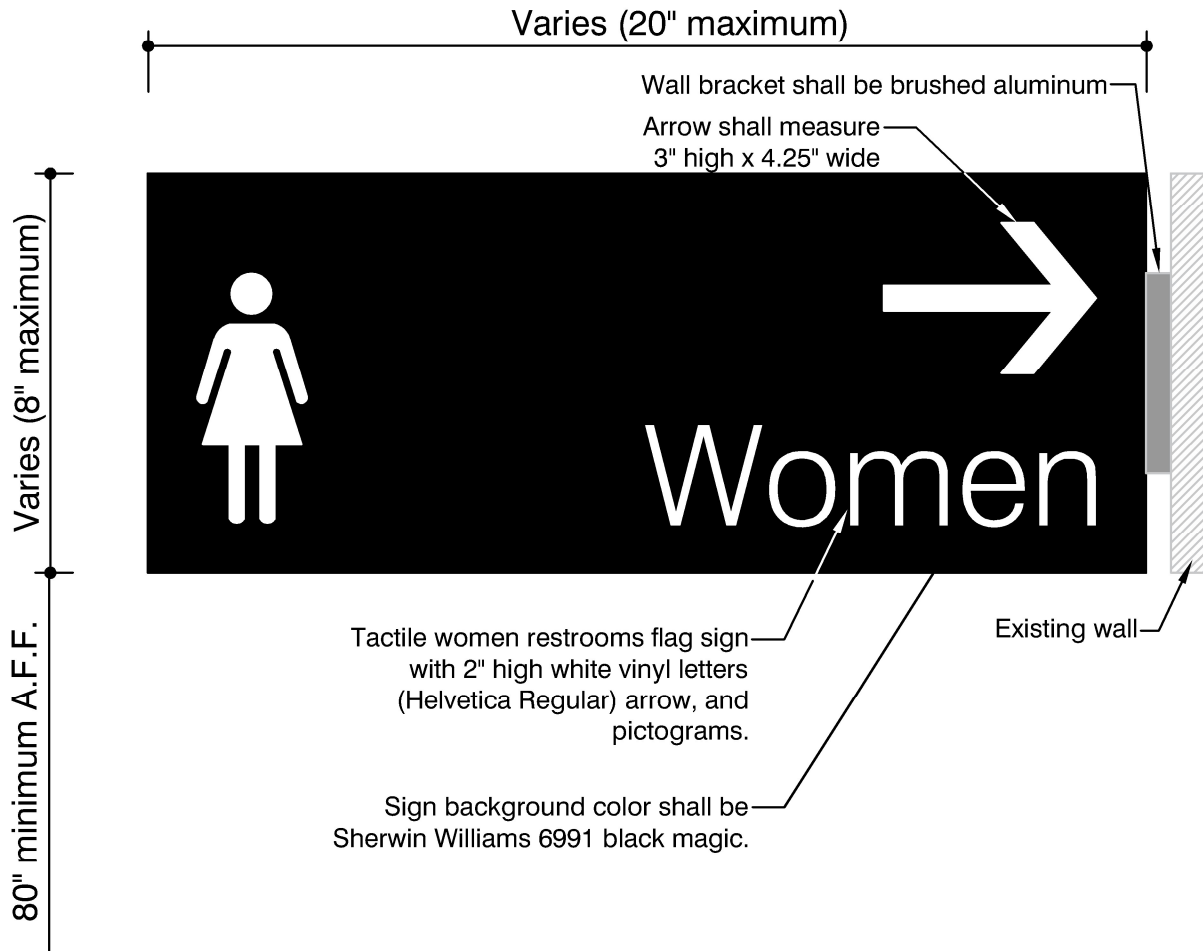

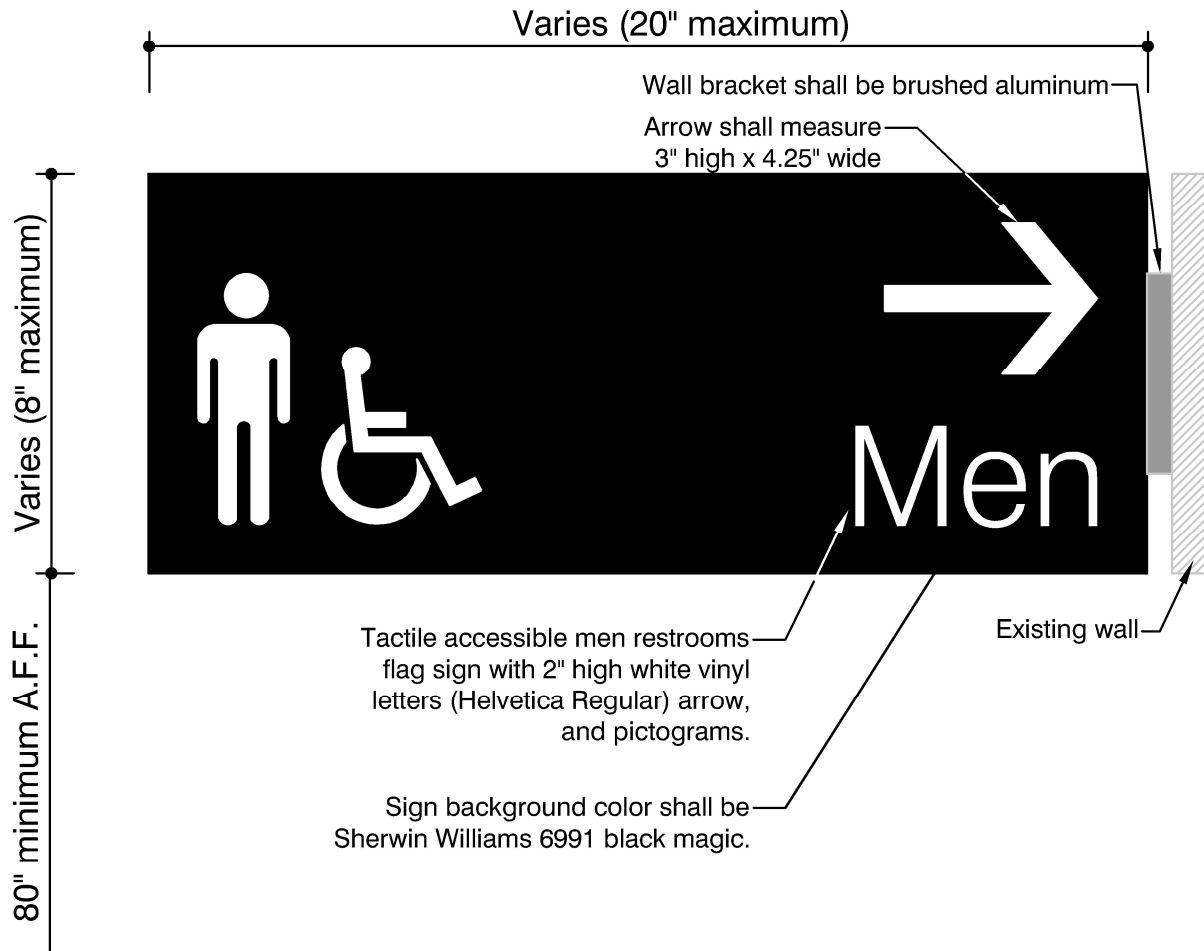

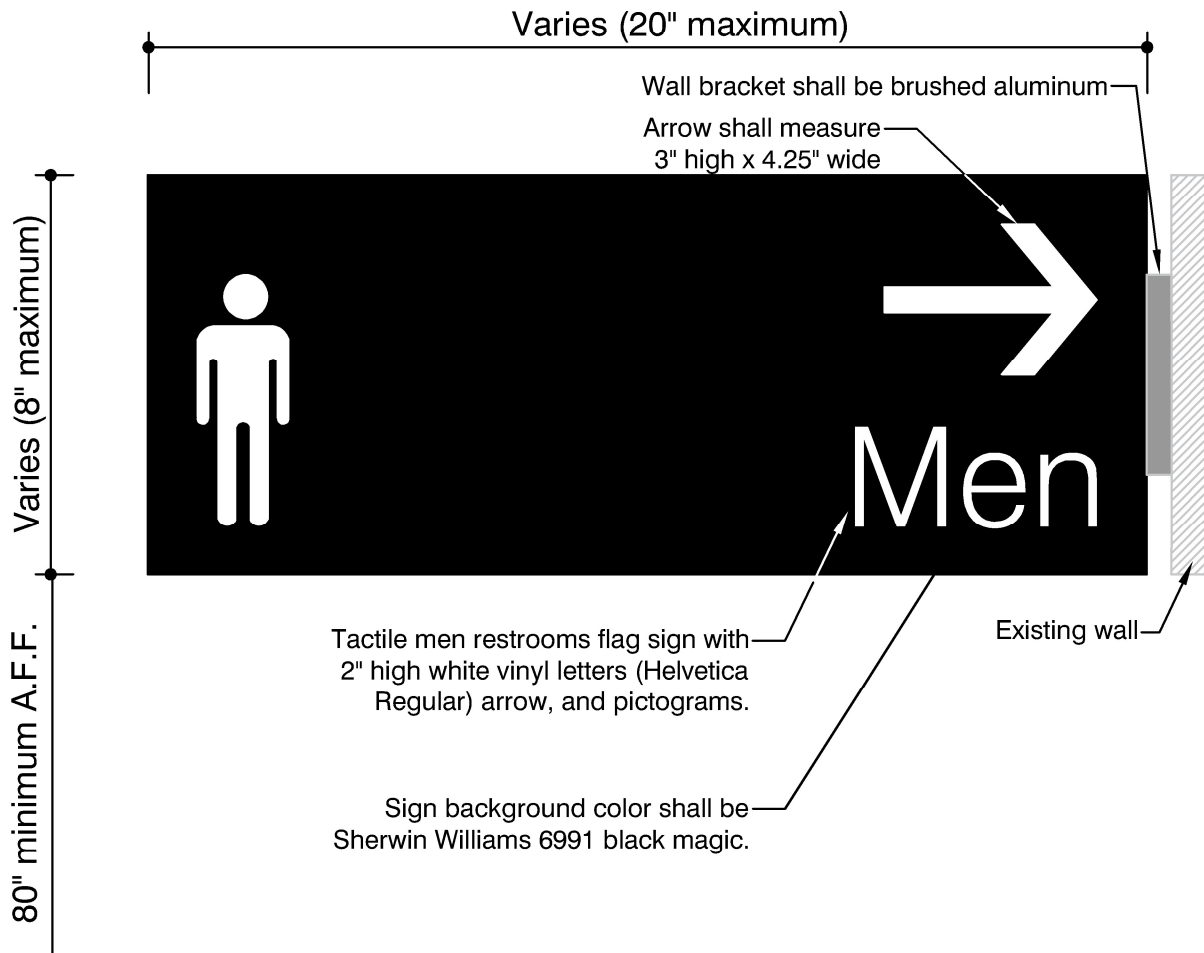

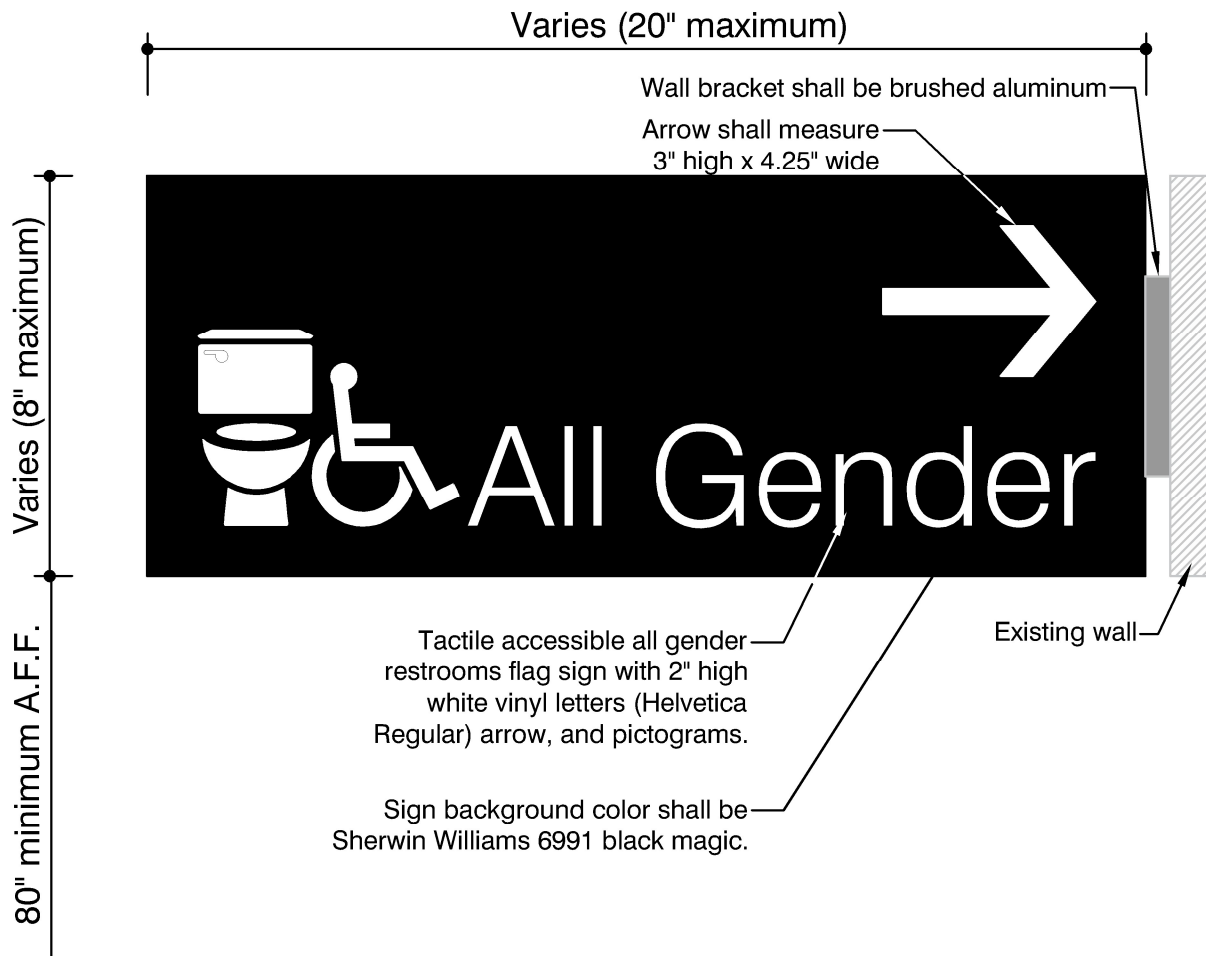

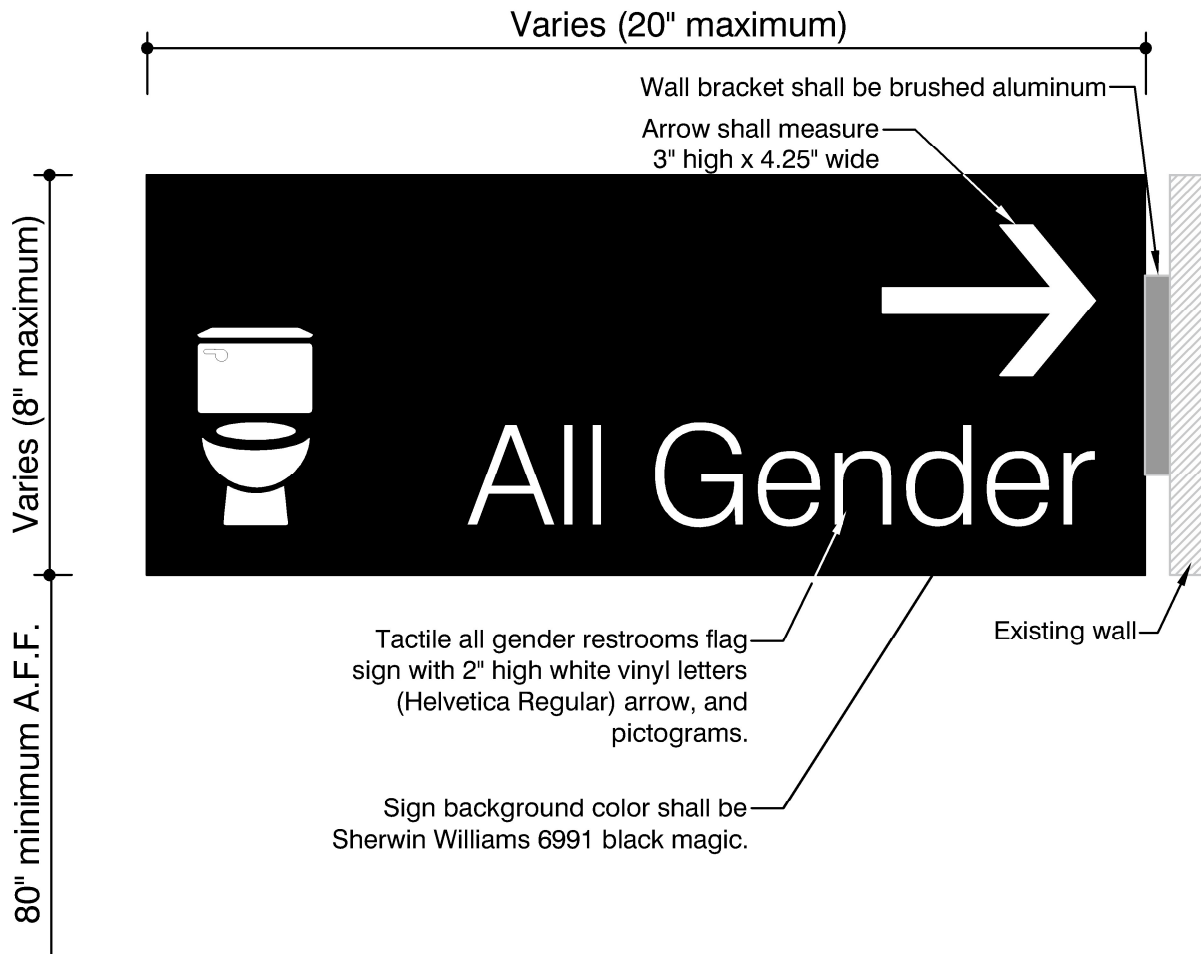

Wayfinding - Flag Sign - Women, Men, Accessible

W-5

ISU Sign Standards

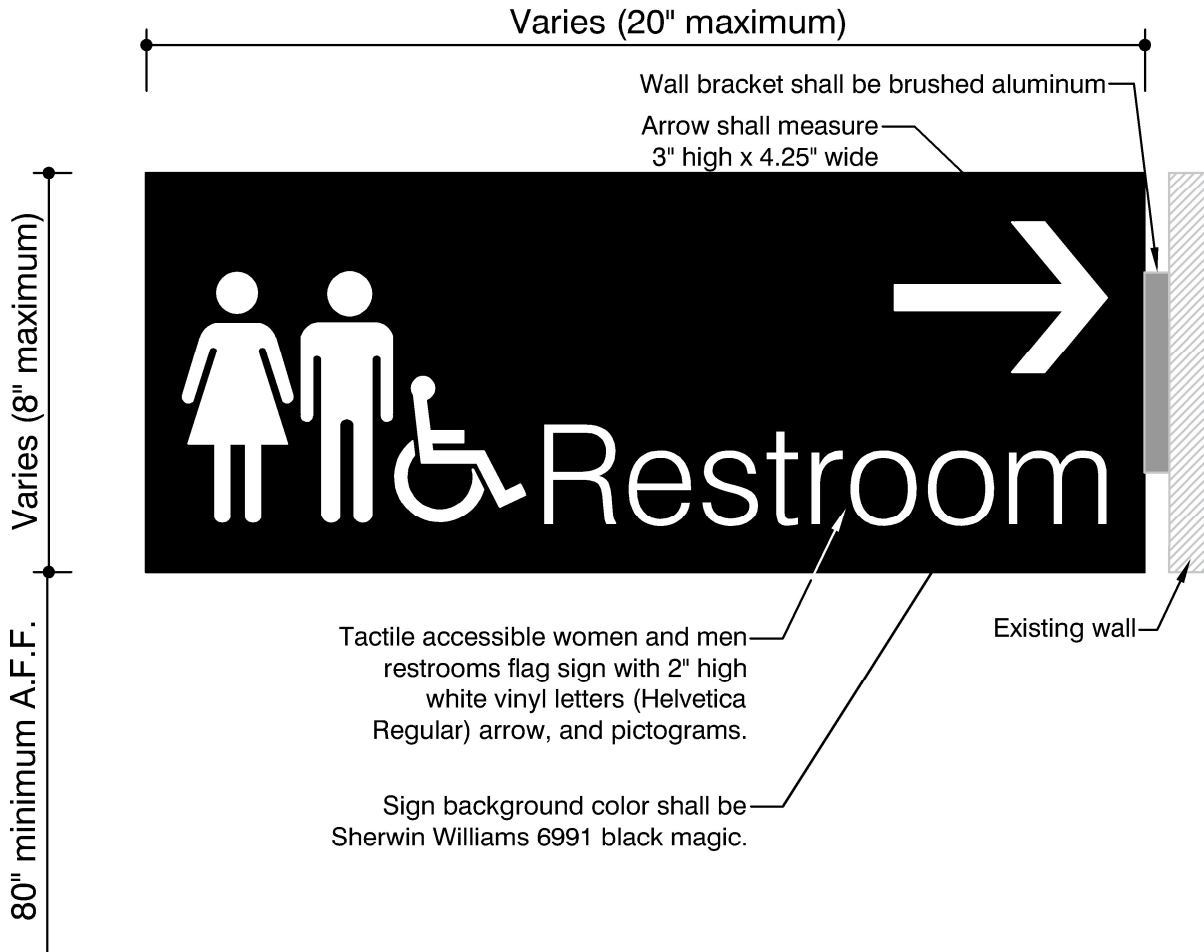

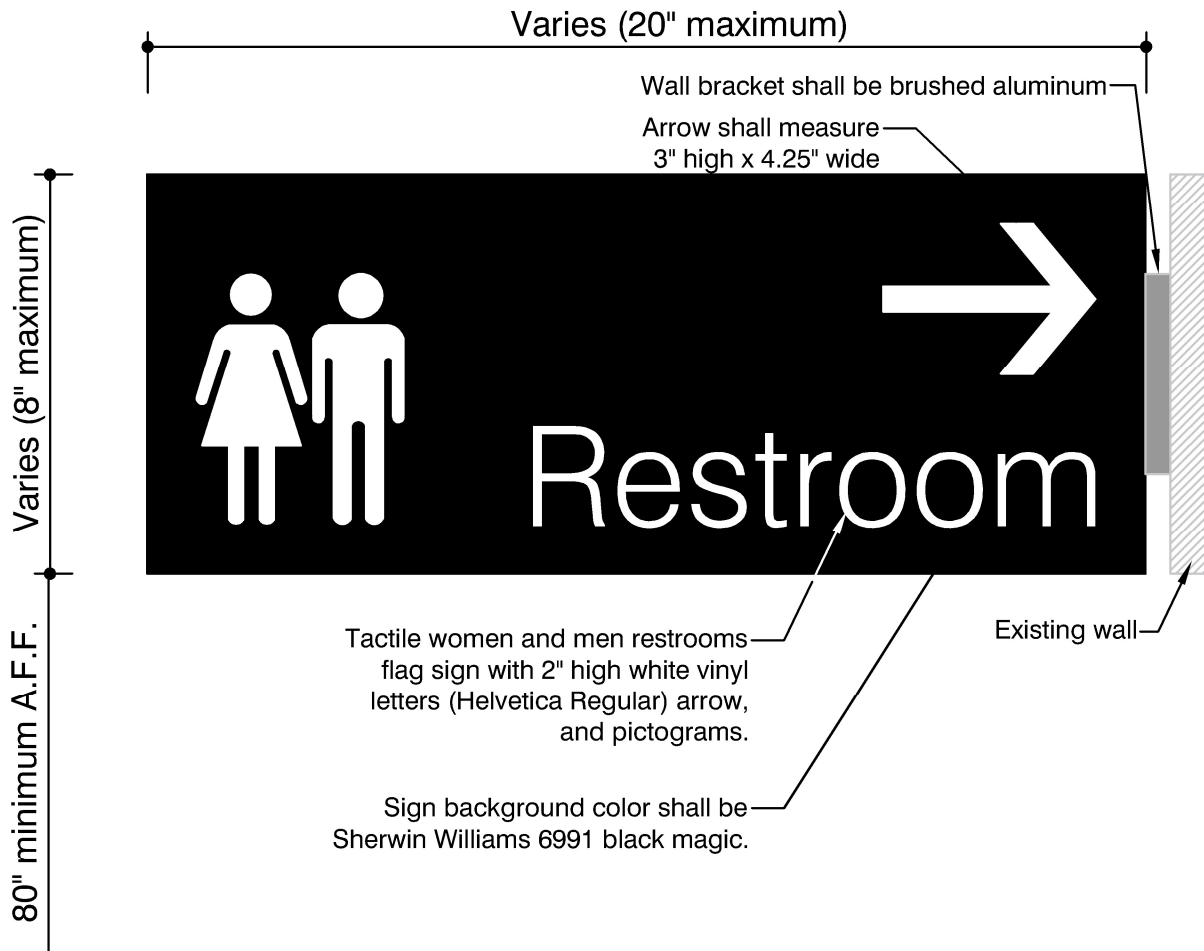

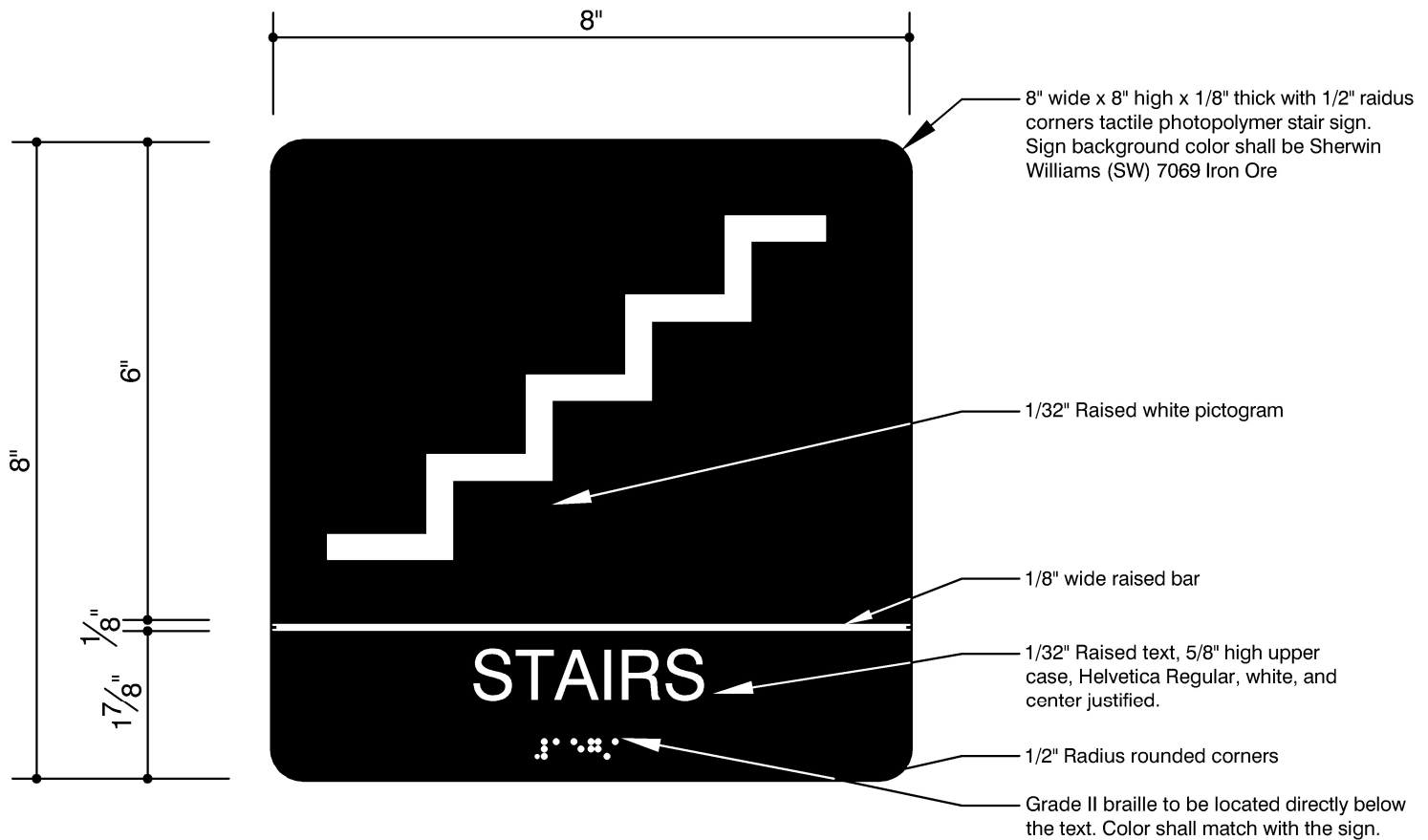

Requirements:

- Submit sample to ISU for approval.
- All signs to meet ADA requirements.
- Two strips of double sided 3 M VHB tape mounting to be included unless otherwise noted.

Stair Identification - In Case of Fire Use Stairs

RG-1.1

ISU Sign Standards



Requirements:

- Submit sample to ISU for approval.
- All signs to meet ADA requirements.
- Two strips of double sided 3 M VHB tape mounting to be included unless otherwise noted.

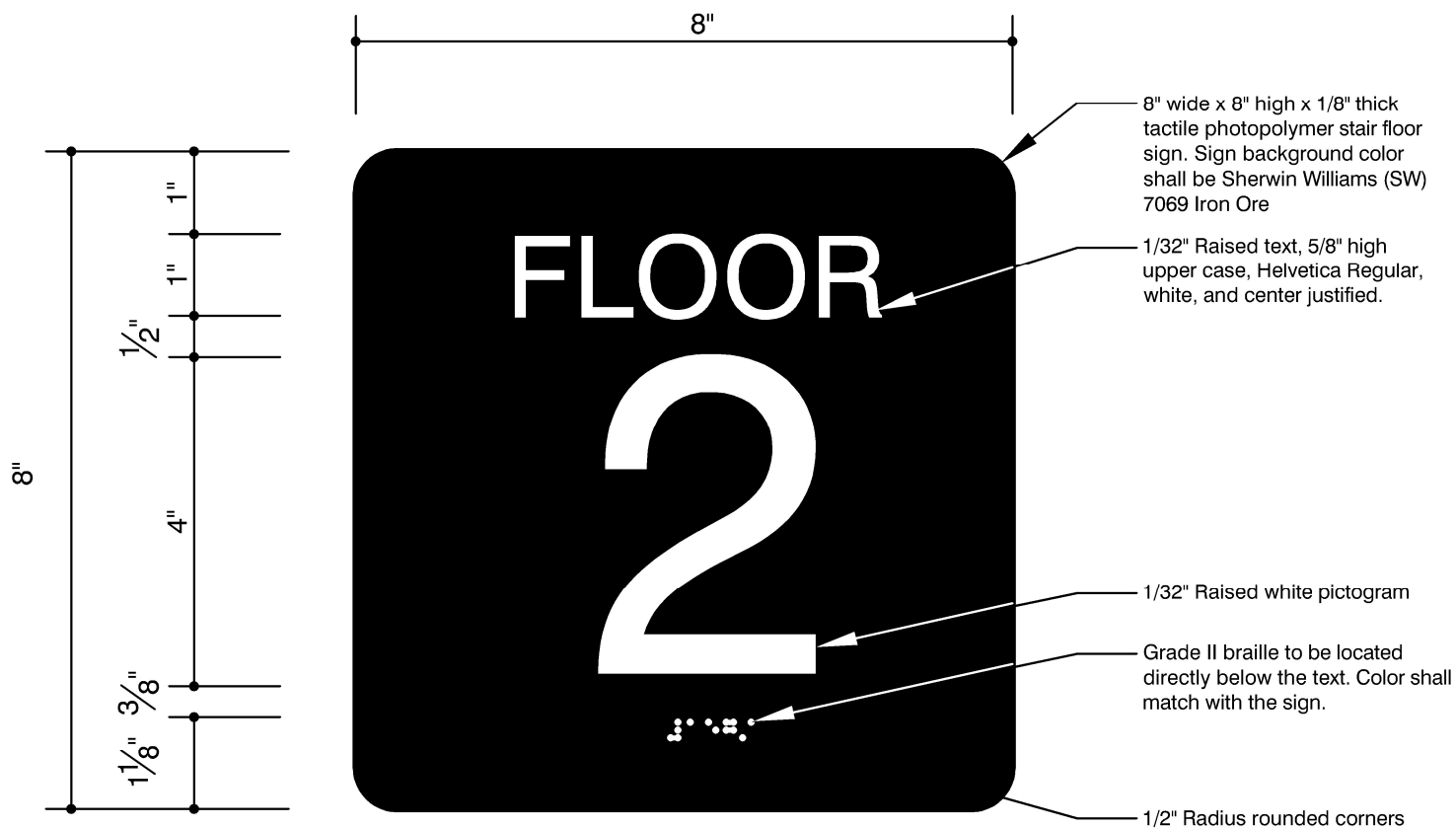

Requirements:

- Submit sample to ISU for approval.
- All signs to meet ADA requirements.
- Two strips of double sided 3 M VHB tape mounting to be included unless otherwise noted.

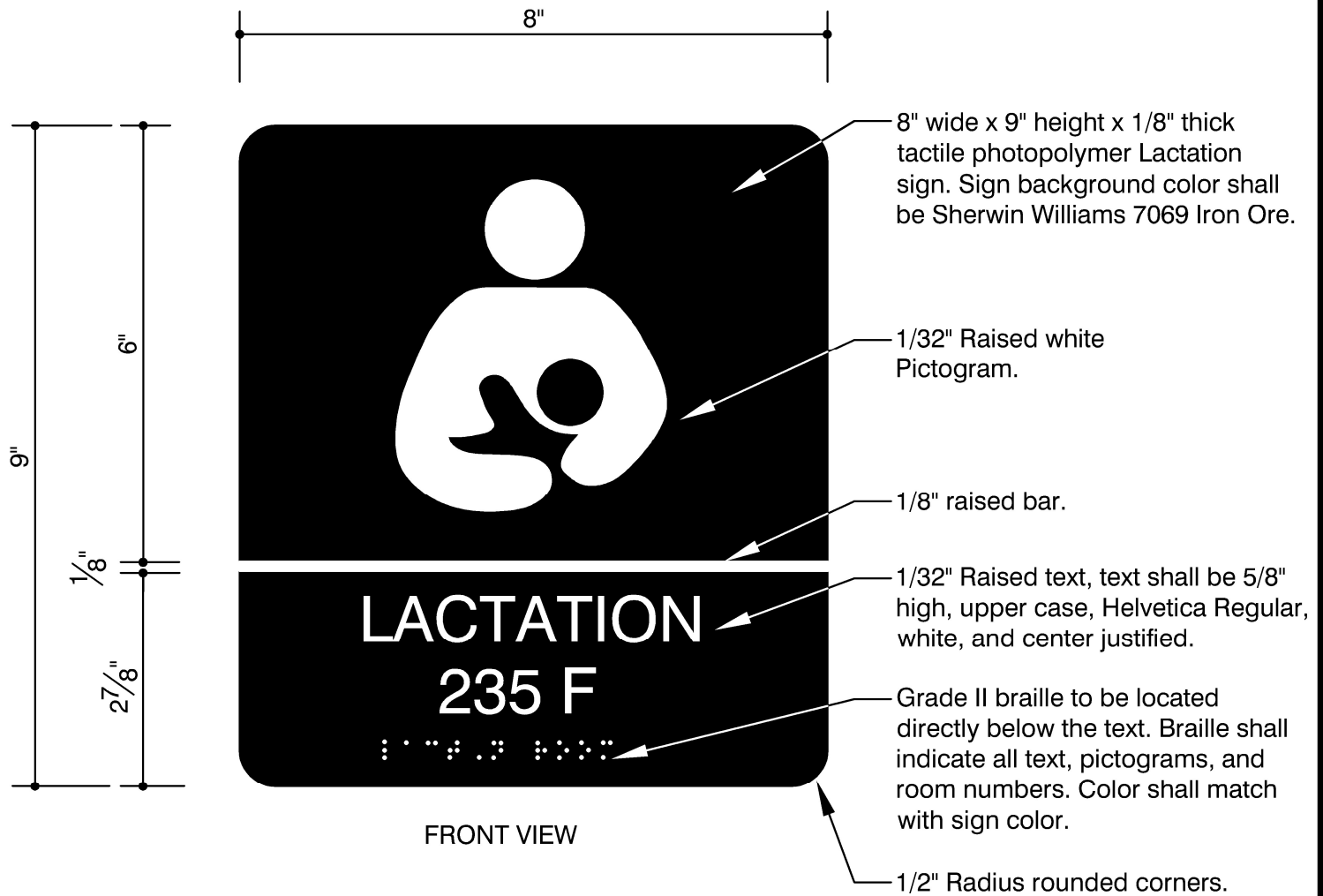

Requirements:

- Submit sample to ISU for approval.
- All signs to meet ADA requirements.
- Two strips of double sided 3 M VHB tape mounting to be included unless otherwise noted.

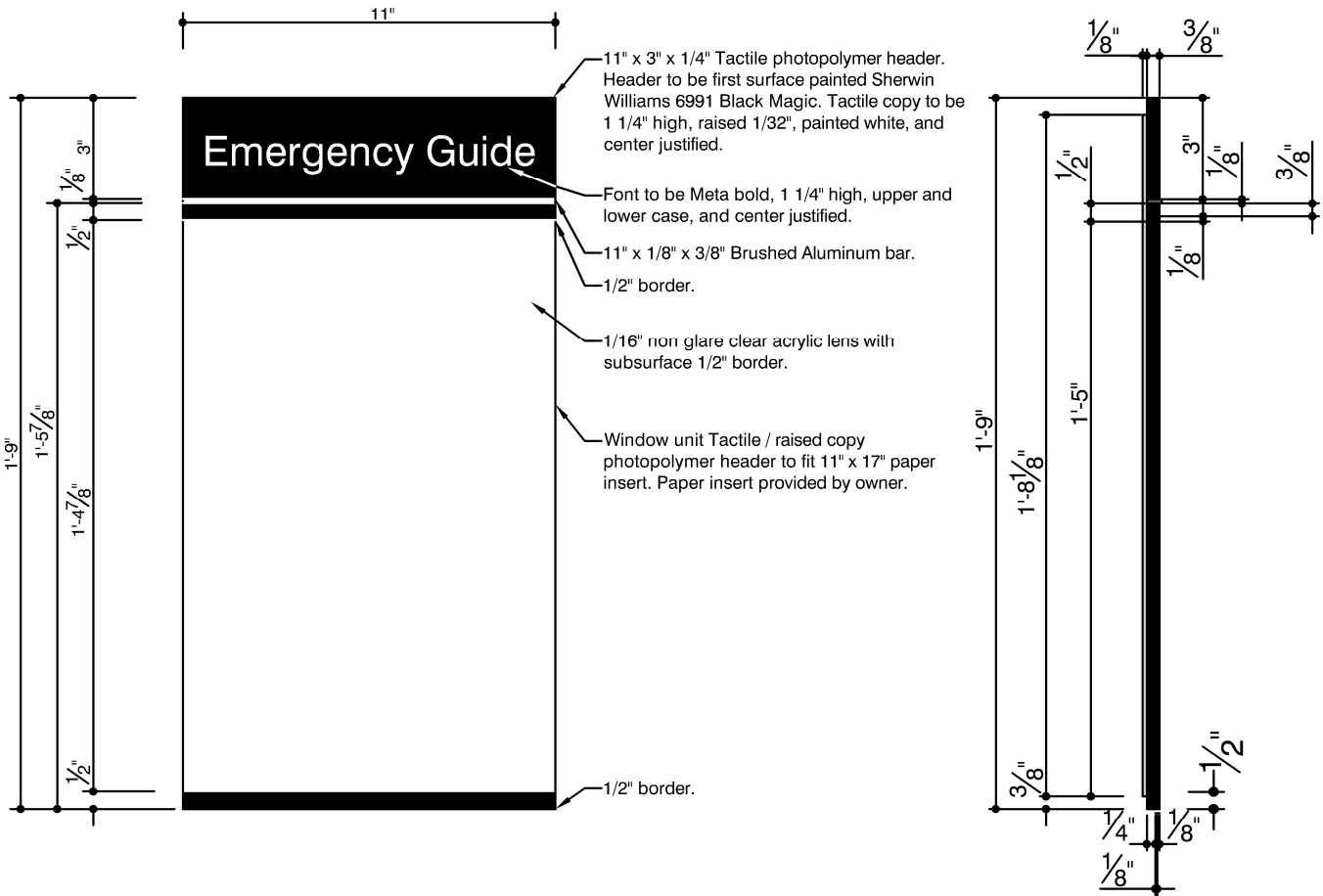

FRONT ELEVATION

SIDE VIEW

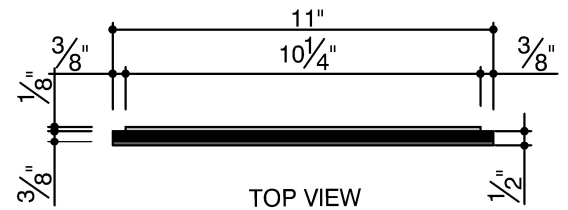

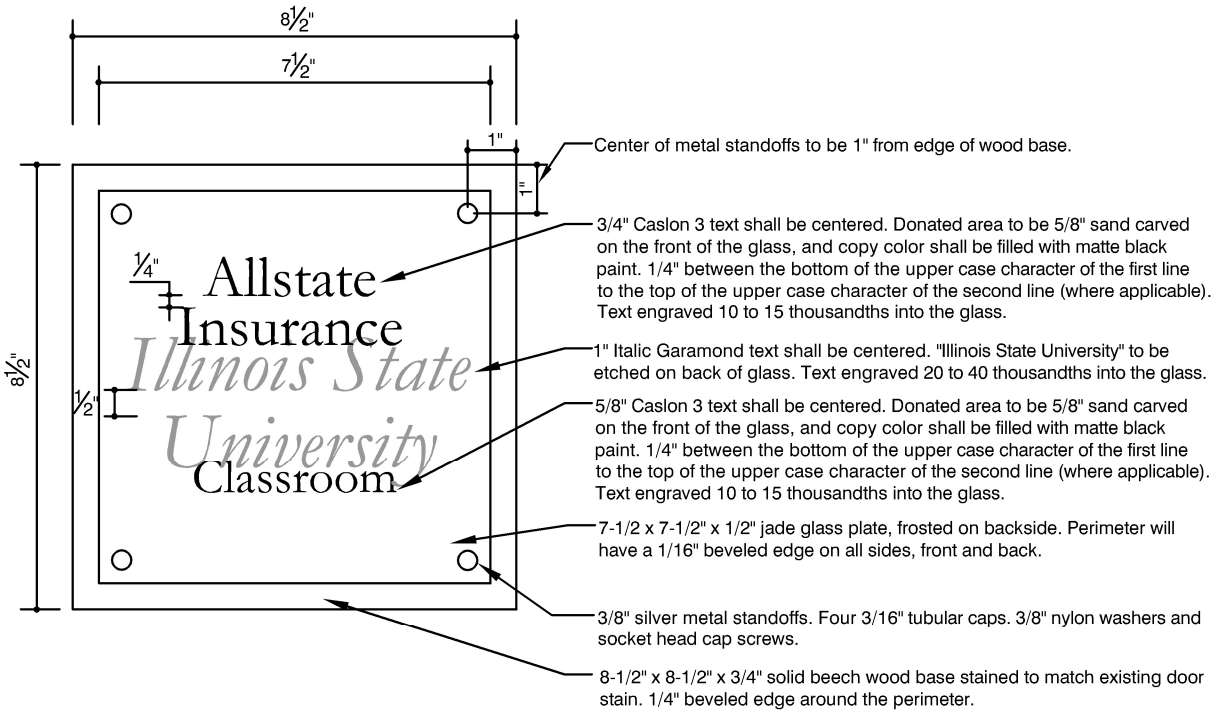

Mounting Information:

- Signs to be mounted on latch side.
- Mounting method will vary depending on the installation.

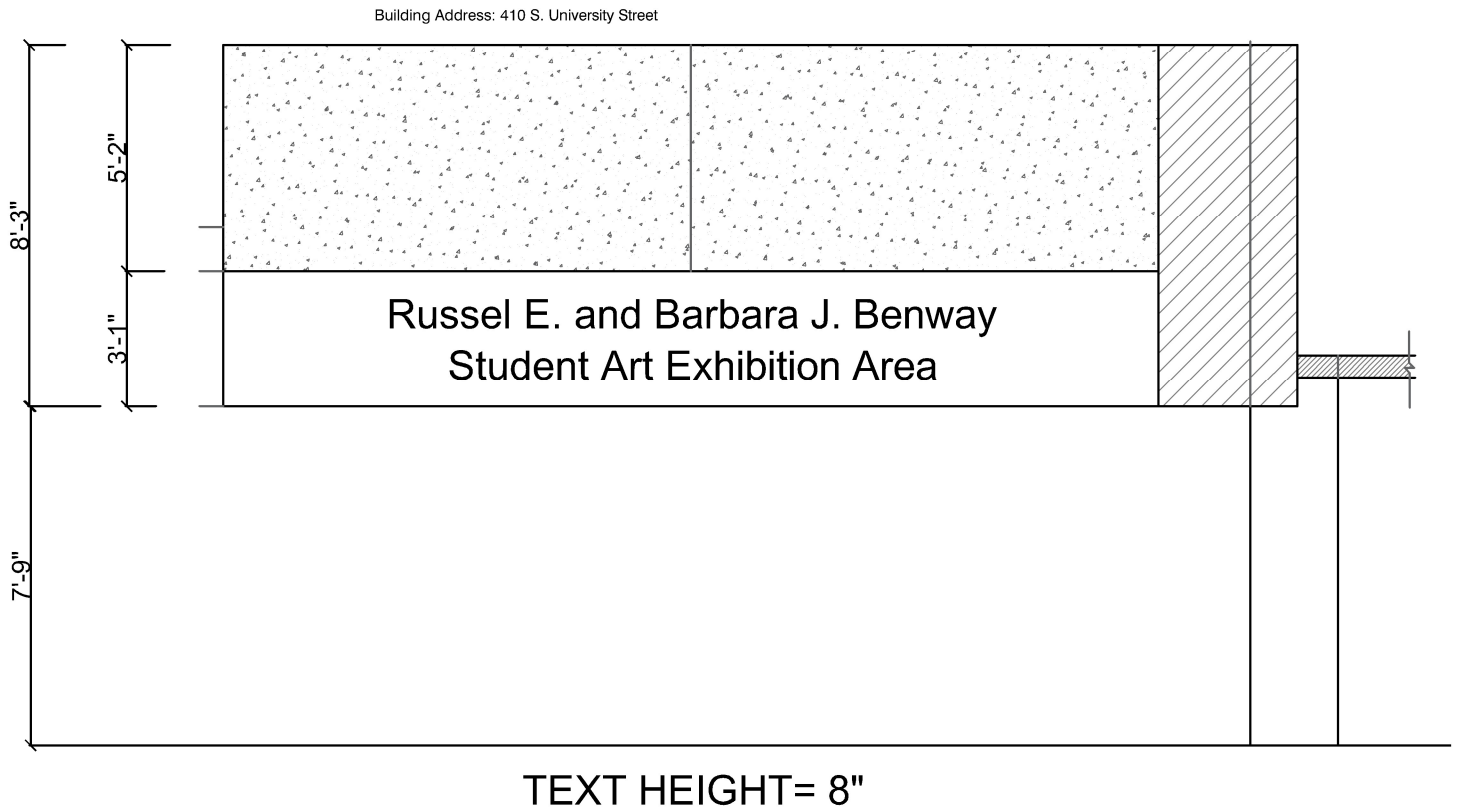

Text:

- Height of letters will vary depending on installation.
- Font - Helvetica Regular.
- Use upper and lower case letters.
- Color of letters shall be black.

Memo Holder - 9" x 11 $\frac{1}{4}$ "

M-1

ISU Sign Standards

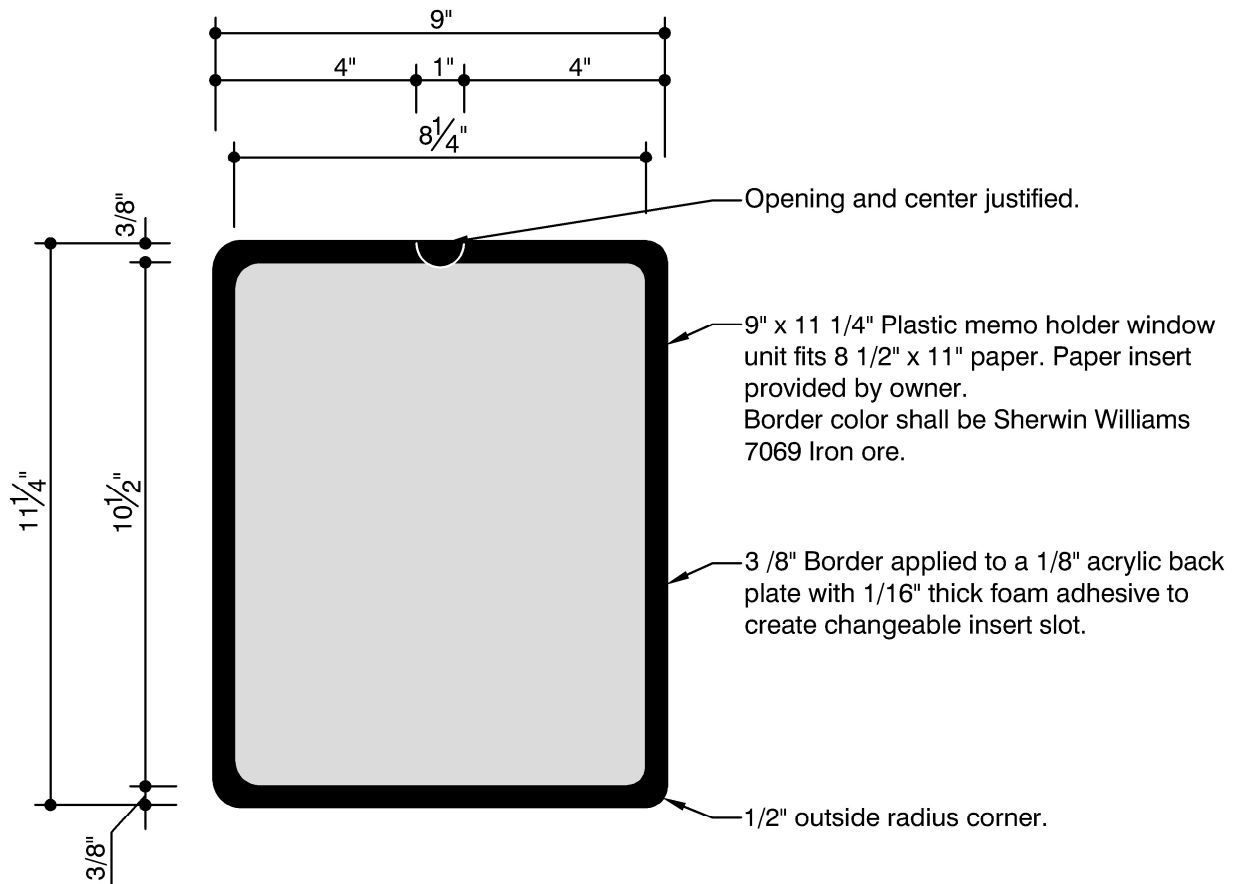

Requirements:

-Two strips of double sided foam tape mounting to be included unless otherwise noted.